

CC-06M

FLUID FLU

UID FLU

DFLUIDA

FLUID FLU

UID FLUID

F L U I D H A N D L I N G M I N I



contents



03 waste oil

28

04 hose reels

30

05

fuel

30

Manual Fuel Pumps

30

Electric Fuel Pumps

31

DEF Pumps

32

Speciality Pumps

35

Meters, Nozzles & Accessories

37

DEF Meters

37

01

greasing

Lever Grease Guns	2
Pistol Grease Guns	4
Mini Grease Guns	6
Air Operated Grease Guns	7
Battery Operated Grease Guns	7
Grease Gun Couplers	8
Grease Gun Accessories	10
Grease Fittings & Accessories	13
Grease Accessory Kits	16
Grease Pumps & Accessories	17
Trolley Mounted Kits - Grease	19

02

oiling

Manual Oil Pumps	19
Air Operated Oil Pumps & Accessories	22
Trolley Mounted Kits -Oil	23
Electric Oil Pumps	23
Double Diaphragm Pumps	24
Oil Meters, Nozzles & Accessories	24



06

drum handling

40

07

air handling

Filters, Regulator & Lubricator	42
FRL Accessories	45
Air Hose Reel	46
Air Blow Gun & Accessories	47
Tyre Inflator Gauges	51

01 greasing

LEVER GREASE GUNS

HEAVY DUTY



10,000 PSI (690 BAR)

- Aluminium die cast head with bulk loader valve and air release valve
- Variable Stroke
- Delivers: Up to 1gm/stroke

G1HD

14oz. (400 gms) / 500cc



G4HD

450 gms
Popular in
Australia
& New Zealand



G10HD

750cc
High
capacity



G18HD

600 gms
Popular in
Italy



STANDARD



6,000 PSI (413 BAR)

- Delivers: Up to 1 gm/stroke
- Capacity: 14 oz. (400 gms)/500cc

G1STD

Steel head



G1DC

Aluminium
die-cast
head



G23

Aluminium powder
coated die-cast
head



SUPA LITE



10,000 PSI (690 BAR)

G1HD-AL

- Light-weight aluminium barrel
- Aluminium die cast head with bulk loader valve and air release valve
- Variable stroke
- Delivers: Up to 1 gm/stroke
- Capacity: 14 oz. (400 gms)/500cc



**25%
LIGHTER**

PROFESSIONAL



8,000 PSI (550 BAR)

G8

- Aluminium die cast head with bulk loader valve
- Variable Stroke
- Delivers: Up to 1 gm/stroke
- Capacity: 14 oz. (400 gms)/500cc



SUPER VALUE



6,000 PSI (413 BAR)

G1

14 oz. (400 gms) / 500cc



- Drop-resistant steel head with bulk loader valve
- Delivers: Up to 1 gm/stroke

G10

750cc
High capacity



G4

450 gms
Popular in
Australia & New
Zealand



G11

1000cc
Extra long & very
high capacity



V SERIES



6,000 PSI (413 BAR)

V1

- Aluminium die cast head fitted with automatic air bleeder valve
- Delivers: Up to 1 gm/stroke
- Capacity: 14 oz. (400 gms)/500cc



JAPANESE STYLE



8,000 PSI (550 BAR)

G81

- Aluminium die cast head with threaded port
- For use with JIABARA cartridge
- Delivers: Up to 0.90 gm/stroke
- Capacity: 400 gms



DUAL PISTON HIGH VOLUME

NEW!



6,000 PSI (413 BAR)

G2

- Dual piston design for 3X grease output per stroke
- No loss of Prime
- Convenience of use in cold weather conditions
- Delivers: Up to 2.4 gm/ stroke

Air Release Valve

Dual Piston Mechanism

Dual Inlet

3X ADVANTAGE
Reduce Greasing Time To One-Third!



SCAN TO WATCH



CLEAR TUBE



10,000 PSI (690 BAR)

G1HD-CL

14 oz. (400 gms)

Variable Stroke



G4HD-CL

450 gms
Popular in
Australia & New
Zealand

Variable Stroke



LEVER OIL GUN



10,000 PSI (690 BAR)

G19

- For use with flowable grease and light oils. Especially useful for pumping glue for water-proofing in construction applications
- Delivers: Up to 1 gm/stroke
- Capacity: 14 oz. (400 gms)/500cc

Variable Stroke



HIGH PRESSURE - HIGH VOLUME

G200

NEW!

- Patented design: Switch from High Pressure to High Volume with the slide of a button
- Aluminium die cast head
- Dual piston mechanism
- Dual Discharge Ports: Front and top port
- Ideal for use on heavy farm equipment, construction machinery & cold conditions
- Capacity: 14 oz (400 gms)/500cc



DUAL OPERATING MODE:

HIGH PRESSURE SETTING



12,000 PSI (830 BAR)

UPTO 0.6 GM/STROKE

HIGH VOLUME SETTING



UPTO 3.2 GM/STROKE

2,000 PSI (130 BAR)

DUAL GREASE GUN PISTOL / LEVER HANDLE

NEW!



7,000 PSI (483 BAR)

G77

- Convenience of a Pistol grip with Power of a Lever Handle
- Dual Discharge Ports: Front and top port
- High Volume – High Pressure adjustable mechanism

Aluminum die cast head fitted with bulk loader & air bleeder valve

PISTOL MODE

LEVER MODE



**4,500 PSI
0.65 gm/stroke**



**7,000 PSI
0.65 gm/stroke**

**5,500 PSI
1.1 gm/stroke**

Pull button & slide to change mode between High Pressure/High Volume



SCAN TO WATCH

PISTOL GREASE GUNS

PROFESSIONAL



7,500 PSI (517 BAR)

G32

- **Patented Feather Touch Design;** max output with minimal effort
- Single piece die cast head & fixed handle for added strength
- **VARIABLE STROKE**
- Delivers: Upto 0.68 gm/stroke
- Capacity: 14 oz. (400 gms)/500cc



'VARIO'



5,000 PSI (345 BAR)

- Aluminium die cast head with drop resistant pistol assembly
- **Adjustable Stroke Mechanism**- easy switch between high Pressure and High Volume modes
- Delivers: Upto 0.84 gm/stroke

G55

14oz.
(400 gms)/500cc

G65

450 gms
Popular in
Australia &
New Zealand



ALL WEATHER



7,000 PSI (483 BAR)

G70

- Ideal for use in cold weather conditions
- **VENTURI MECHANISM** and large grease inlet helps retain prime
- Delivers: Upto 0.68 gm/stroke
- Capacity: 14 oz. (400 gms)/500cc



ALL WEATHER - ADJUSTABLE



6,000 PSI (413 BAR)

- Ideal for use in cold weather conditions
- **VENTURI MECHANISM** and large large grease inlet helps retain prime
- **ADJUSTABLE MECHANISM** - easy switch between high pressure and high volume modes
- Delivers: Upto 0.90 gm/stroke

G80

14 oz.
(400 gms)/500cc

G85

450 gms
Popular in
Australia & New
Zealand



STANDARD



5,000 PSI (345 BAR)

G5

- 14oz. (400 gms)/ 500cc
- Aluminium die cast head with block nut
 - Delivers: Up to 0.50 gm/stroke



G4PST

450 gms
Popular in
Australia &
New Zealand



G5PRO

14 oz. (400 gms)/
500cc
Professional model:
Head fitted with
bulk loader and air
release valve.
Grip on movable
handle



DUAL DISCHARGE



5,000 PSI (345 BAR)

G31

- Heavy duty Aluminium die cast head
- Dual Discharge ports - front and top port for convenient greasing in inaccessible areas
- Delivers: Up to 0.50 gm/stroke
- Capacity: 14 oz. (400 gms)/500cc

1

2



1 Top Port



2 Front Port



SUPA-LITE



5,000 PSI (345 BAR)

G31-AL

- Light-weight Aluminium Barrel
- Aluminium die cast head fitted with block nut
- Dual Discharge ports - front and top port for convenient greasing in inaccessible areas
- Delivers: Up to 0.50 gm/stroke
- Capacity: 14oz. (400 gms)/500cc



**25%
LIGHTER**

All grease guns are available in 1/8" BSPT, M10x1, 1/8" NPT threads. Available with rigid steel extension with coupler or flexible hose with coupler.

HIGH PRESSURE - HIGH VOLUME

G500

- Patented design: Switch from High Pressure to High Grease Volume with the simple slide of a button.
- Aluminium die cast head with bulk loader valve
- Dual piston mechanism
- Dual Discharge Ports: front and top port
- Ideal for use on heavy farm equipment, construction machinery & cold conditions



DUAL OPERATING MODE

HIGH PRESSURE SETTING



10,000 PSI
(690 BAR)

UPTO
0.4GM/STROKE

HIGH VOLUME SETTING



UPTO 1.3 GM/
STROKE

2,000 PSI
(130 BAR)

NEW!

CLEAR TUBE



5,000 PSI (345 BAR)

- Tough, impact and drop resistant polycarbonate tube with Aluminium die cast adaptors
- For quick and convenient identification of lubricant eliminating the risk of cross contamination or mixing of incompatible greases
- Delivers: Up to 0.50 gm/stroke

G5-CL

14 oz.
(400 gms) /
500 cc



G4PST-CL

450 gms
Popular in
Australia &
New Zealand



DOUBLE LEVER

G83



7,500 PSI (517 BAR)

- Screw-in cartridges works on special 'Vacuum Technology' - ensures
 - Full utilisation of grease in the cartridge
 - No priming needed
- Delivers: Upto 0.80 gm/stroke

G83F

For use with F type (500 gm) threaded grease cartridges



G83F-MTO

For use with both F type (500 gms) and LS type (400 gms) threaded grease cartridges



SPIN-ON GREASE GUNS

- Cartridge works on special 'Vacuum Technology' ensuring
 - Full utilisation of grease in the cartridge
 - No priming needed
- Fast and easy reloading
- No air pockets so no air bleeding needed
- For use with 400 gm LS type threaded grease cartridge.



1 Screw-In

2 Spin-On

3 Get Going!

Threaded port for screwing cartridge



SCAN TO WATCH

LEVER MODEL

G48



6,000 PSI (413 BAR)

Delivers: Upto 0.90 gm/stroke



PISTOL MODEL

G48P



5,000 PSI (345 BAR)

Delivers: Upto 0.50 gm/stroke



'V SERIES'



5,000 PSI (345 BAR)

V5

- Aluminium die cast head fitted with automatic air release valve
- Delivers: Up to 0.50 gm/stroke



THREADED CARTRIDGE ADAPTOR

NEW!

ADP-CTG

- Polypropylene adaptor converts any standard grease gun to a SPIN-ON style gun
- Adaptor fits onto grease gun head making it compatible with LS style threaded grease cartridges



3 Simple Steps



01 Unscrew the grease gun barrel from head



02 Thread in the Greasing Adaptor into the grease gun head



03 Screw on cartridge & get going!

MINI GREASE GUNS

MINI PUSH TYPE



1,000 PSI (69 BAR)

- Lubricate hammer mechanism in Impact Wrenches with flush type grease Fittings
- Comes with needle nozzles: 0.028" (0.7 mm), 0.039" (1.0 mm) & 0.055" (1.4 mm)
- Delivers: Upto 0.3 gms/ stroke
- Capacity: 3oz. (85 gms)
- For use with bulk grease only

G3P

Black powder coated finish
Steel barrel for regular greasing applications



G3P-CL

Clear Tube
Tough, impact and drop resistant clear tube barrel with aluminium barrel for quick identification of grease



MINI PISTOL - POPULAR



3,000 PSI (207 BAR)

G15

- Tool box size gun with a push type operating mechanism
- Delivers: Upto 0.40 gms/ strokes
- For use with 3 oz. (85 gms) grease cartridge only



GREASE TUBE DISPENSER

G5P

Ideal for precise greasing in narrow spaces
Precision milled parts with spring operated pumping system

Comes with 2 applicators:

- Fine applicator: for fine line greasing
- Coarse applicator: for thick greasing

Delivers upto 0.25gm/stroke
(0.5 oz./57 strokes)

Ideal for lubricating

- Pedals
- Hubs
- Bottom brackets
- Headsets
- Impact Wrenches

Also available with 3.5 oz. (85 gm) calcium carbonate grease tube



COARSE APPLICATOR	FINE APPLICATOR

NEW!



G5P/GRS-1/3.5T/CC

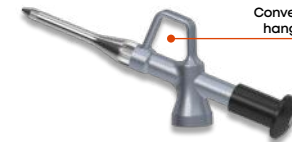

Convenient hang hole

G5P

MINI PISTOL - DELUXE



3,500 PSI (240 BAR)

- Dual Discharge ports- Top port for convenient greasing in inaccessible areas
- Delivers: Upto 0.40 gms/stroke
- For use with 3 oz. (85 gms) grease cartridge

G16

Black powder coated finish



G16-ZN

Zinc plated finish



G16-CL

Clear tube



G16-MR

For marine applications aluminium barrel with Stainless steel-304 handle, end cap & links



NEW!

QUICK GREASE FILLER GUN

NEW!

SG-GR

- Filler gun for quick filling high viscosity grease in cylinders of central lubrication system



MINI - LEVER



6,000 PSI (413 BAR)

G14

- Tough little grease gun for hard to reach places
- Delivers: 0.55 gms/strokes
- For use with 3oz. (85 gms) grease cartridge



PUSH TYPE

- Toolbox size gun used for greasing Impact Wrenches, Lawn Mowers, Chain Saws, Trailers etc.
- Works on a push type mechanism with bulk grease only
- Delivers: Upto 0.90gm/shot

G6P

30cm³

G7P

125cm³



All grease guns are available in 1/8" BSPT, M10x1, 1/8" NPT threads. Available with rigid steel extension with coupler or flexible hose with coupler.

AIR OPERATED GREASE GUNS

DUAL MODE

NEW!



6,000 PSI (413 BAR)

- Fully automatic free flow & single shot / Grease discharge in ONE GUN
- Designed for applications requiring frequent greasing such as in automotive workshops, manufacturing facilities etc.
- 30" flexible hose with coupler
- **Pressure Ratio - 40:1**
- **Air compressor volume:** 1 CFM @ 6 BAR
- **Delivers:**
 - In One shot mode:** Upto 0.90 gm/stroke
 - In continuous mode:** Upto 400 gm/minute

APGG1

Capacity: 14 oz. (400 gms)/500cc

APGG4

Capacity: 450 gms suitable for Australia & New Zealand



EASY SWITCH BETWEEN MODES



Slide backwards for CONTINUOUS MODE



Press button for ONE SHOT OPERATION



SCAN TO WATCH

STANDARD



4,800 PSI (330 BAR)

INTERMITTENT MODEL

- Grease discharge with every press of trigger
- **Delivers: Upto 0.90 gms/stroke**
- **Pressure Ratio - 40:1**

PGG1

Capacity: 14 oz. (400 gms)/500cc



PGG4

Capacity: 450 gms Popular in Australia & New Zealand



AUTOMATIC / CONTINUOUS MODEL

- Continuous Grease discharge with the trigger pressed
- **Delivers: Upto 400 gms/ minute**

AGG1

Capacity: 14 oz. (400 gms)/500cc



AGG4

Capacity: 450 gms Popular in Australia & New Zealand



HIGH POWER



6,000 PSI (413 BAR)

G64

- One shot grease gun
- For use in factory maintenance, farm, fleet service or for use from vehicle air brake compressors
- **Pressure Ratio - 50:1**
- **Delivers: 0.68 gm/shot**



BATTERY OPERATED GREASE GUNS

CORDLESS



10,000 PSI (690 BAR)

CGG

- 20V high torque motor
- 2 Speed Design:
 - High Pressure:** Up to 10,000 PSI (690 BAR)
 - Low Pressure:** Up to 7,500 PSI (517 BAR)
- 2000 mAh, 18.5V Lithium-ion Battery
The battery charge time: 1 hour
- Integrated LCD display panel indicates
 - Battery level, grease level, unit of dispensing & pump speed
- **Delivers:** Up to 85 gm/min

INCLUDES



Grease gun hose with coupler



Lithium-ion battery (1)



Quick battery charger



Shoulder strap



Blow mounded case



1 FULL CHARGE

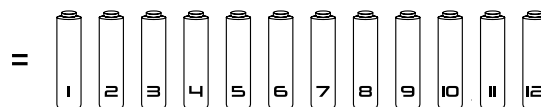

12 CARTRIDGES DISPENSED
14 oz. (400 gm)



NEW!

USB RECHARGEABLE BATTERY GREASE GUN



8,000 PSI (550 BAR)

RGG/12L

- World's 1st USB Rechargeable Battery Grease Gun
- Eliminates the need for compatible batteries and chargers
- In-built, lightweight and compact 2000 mAh Li-ion battery powers the 12V motor

- **Delivers: 87 gms/ min**



1 FULL CHARGE

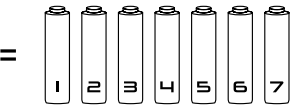

**7 CARTRIDGES DISPENSED
14 oz. (400 gm)**



Replacement Hose



3 Jaw Coupler



Charging Cable Included

Air release valve releases trapped air in grease



NEW!

Inbuilt battery

BATTERY POWERED



6,000 PSI (413 BAR)

BPGG

- 18.5 V Li-Ion battery operated gun
- Delivers: Up to 85 gms/min.
- With 30" (750 mm) high pressure hose with spring guard and 4 jaw coupler



1 FULL CHARGE

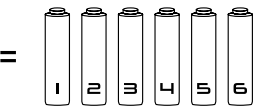

**6 CARTRIDGES DISPENSED
14 oz. (400 gm)**

INCLUDES



Blow mounded case



Battery Charger



Battery packs



Shoulder strap



30" (150 mm)
High pressure hose with spring guard



GREASE GUN COUPLERS

QUICK LOCK



8,000 PSI (550 BAR)

Quick disconnect coupler for convenient operation

HC21

Regular

1-3/16" (30 mm)
17 mm



HC21L

Extra long

2-5/32" (80 mm)
17 mm



Engagement at 6 points

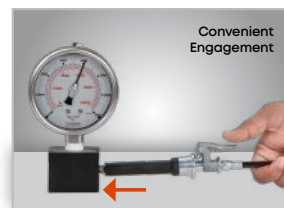

Convenient Engagement



Easy Release



NO MORE MESS



NO MORE BROKEN JAWS

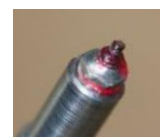

NO MORE BROKEN GREASE FITTINGS



SCAN TO WATCH

SUPER GRIP QUICK CONNECT

NEW!



5,000 PSI (345 BAR)

Compact & easy access coupler works with a 'Forward Push' mechanism for engaging & dis-engaging

HC23



Convenient Engagement



Easy Release

STANDARD



3,000 PSI (207 BAR)

HC10

Without Ball Check

HC11

With Ball Check



0.59" (15 mm)



Also available in 54 pcs Set

For hand operated grease guns only

SLIM LINE



6,000 PSI (413 BAR)

HC19

Without Ball Check



0.54" (13.7 mm)

For hand operated grease guns only

MACHINED JAW



6,000 PSI (413 BAR)

HC24

Without Ball Check



0.59" (15 mm)

One piece construction

For hand operated grease guns only

PROFESSIONAL



6,000 PSI (413 BAR)

HC14

With Ball Check

HC18

Without Ball Check



0.59" (15 mm)



Also available in 54 pcs Set

For hand operated grease guns only

HEAVY DUTY



10,000 PSI (690 BAR)

HC12

With Ball Check



0.67" (17 mm)

For hand & air operated grease guns only

GREASE GUN SWIVEL



3500 PSI (240 BAR)

SWV

• Extension swivel threaded 1/8" M x 1/8" F



SPECIALITY GREASE COUPLERS



7,500 PSI (517 BAR)

HCP

AIR-O
Use with grease control valves



1,000 PSI (69 BAR)

HCR

RIGHT ANGLED -90°
Useful in restricted/
confined spaces



7,000 PSI (483 BAR)

HCSW

SWIVELLING - 360°
With Ball Check



3,000 PSI (207 BAR)

HC13

PIN TYPE
Used with Pin type
Grease Fittings



BUTTON HEAD COUPLERS



3,000 PSI (207 BAR)

BHC10

SWIVELLING
5/8"(16 mm) Button
Head Grease
Fittings



PCN1

FIXED PUSH-ON
5/8"(16 mm) Button
Head Grease
Fittings



HOC1

HOOK ON
5/8"(16 mm) Button
Head Grease
Fittings



4,000 PSI (276 BAR)

PCN3

MEDIUM DUTY PUSH-ON
5/8"(16 mm) Button
Head Grease Fittings



PCN2

HEAVY DUTY PUSH-ON
7/8"(22 mm) Button
Head Grease Fittings



360° SLIM LINE SWIVEL COUPLER



3,000 PSI (207 BAR)

HCSW11

Convenient access into narrow, inaccessible greasing joints



NEW!

GREASE GUN ACCESSORIES

HEAVY DUTY GREASE GUN HOLDER

GGH03

Suitable for use with almost all sizes of grease guns



GREASE GUN HOLDER

GGH01

Suitable for 14 oz. (400 gm) grease guns



GREASE GUN LED LIGHT

GGL

- Fits on grease hose/steel extension
- Useful in dark areas to locate shoulders, inaccessible greasing points etc.



GENERAL MULTI-PURPOSE EP GREASE

GRS-CC



NLGI #2
GC-LB



- Multi-purpose calcium complex grease with strong anti-wear properties for high-pressure applications in industrial, automotive & home usage
- Oxidation resistant formulation and corrosion protection properties extends equipment life

RECOMMENDED FOR

- Lubrication of wheel hub bearings, chassis and suspension of buses, trucks, and other transportation vehicles.
- All types of plain and antifriction Ball and Roller Bearings and Bushings, Rack and Pinion, Gears, Linkages, Slides, Universal joints, Kingpins, Guides, Chains, Centralized lubrication systems, Electric motors, Pumps, EOT Cranes, Forklifts and other greasing applications.

MARINE EP GREASE

GRS-CS



NLGI #2
GC-LB



- Premium water resistant calcium sulfonate marine grease. Unique additives with special adhesive properties provide maximum lubrication even under most severe applications
- Timken OK load of 55 pounds

RECOMMENDED FOR

- Chassis, wheels, plain and anti-friction bearings, fifth wheel plates, springs, trailers, open gears, pivot joints / shafts, outboard motor steering

HEAVY DUTY EP GREASE

GRS-PU



NLGI #2
GC-LB



- Long lasting Polyurea, washout-proof heavy-duty grease
- All temperature stable with outstanding film strength & strong adhesive properties makes it ideal for severe duty applications trucks, combines, construction equipment, lawn and ground equipment, & in industrial and automotive applications

RECOMMENDED FOR

- High-speed bearings, axle bearings, and universal joints

GREASE GUN HOSES



3,500 PSI (240 BAR)

GHC

- Thermoplastic construction with
- Burst Pressure: Upto 11600 PSI (800 BAR)
- For hand grease guns only

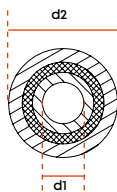

d1: Inner dia - 0.14" (3.6 mm)
d2: Outer Dia. - 0.33" (8.5 mm)



Standard lengths: 6" (150 mm), 8" (200 mm), 9" (225 mm), 10" (250 mm), 12" (300 mm), 18" (450 mm) & 20" (500mm)

Standard

With Professional 4 Jaw Coupler

With Spring Guard

With Swivel

HEAVY DUTY GREASE GUN HOSES



5,800 PSI (400 BAR)

GHCHP

- Superior Construction: Polyamide inner tubing with polyurethane sheathing reinforced diagonally in highly tear resistant polyester
- Burst Pressure: Upto 13,775 PSI (960 BAR)
- For hand and air operated grease guns

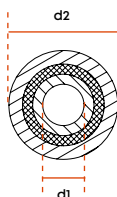

d1: Inner dia - 0.16" (4.1 mm)
d2: Outer Dia. - 0.425" (11 mm)



Standard lengths 12" (300 mm), 18" (450 mm) & 20" (500 mm)
Other lengths can be custom manufactured

Standard

With Professional 4 Jaw Coupler

With Spring Guard

All grease gun accessories are available in 1/8" BSPT, M10x1, 1/8" NPT threads.

**FLEXIBLE/RIGID
GREASE GUN EXTENSIONS**



5,000 PSI (345 BAR)

FRC

- 13" (300 mm) rigid steel extension with flexible hose extension
- Comes complete with coupler

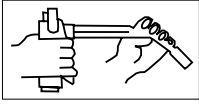

Switches with one hand

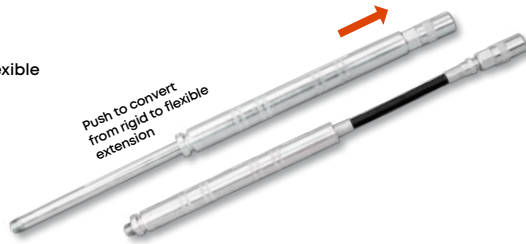

GREASE GUN EXTENSIONS



6,000 PSI (413 BAR)

GBP

BENT
6", 8", 18"



GSP

STRAIGHT
4", 5", 6" 8"



**GREASE
INJECTOR NEEDLES**



6,000 PSI (413 BAR)

GIN/00

16 Gauge

GIN/01

18 Gauge



GIN/01

GIN/02

21 Gauge

GIN/03

SAFETY with aluminium holder



GIN/03

SEAL OFF DISPENSER

SOD

Useful for lubricating cars with grease plugs

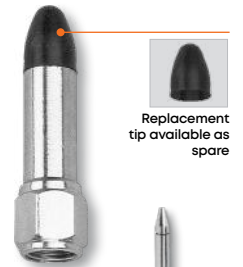

NEEDLE NOSE DISPENSERS



6,000 PSI (413 BAR)

DNN/1-8

Needle Length:
19/32" (15 mm)
Needle Dia:
0.187" (4.76 mm)



DNN/1-8/S

Needle Length:
19/32" (15 mm)
Needle Dia:
0.187" (4.76 mm)



DNN/1-1-2

Needle Length:
1.1/2" (38 mm)
Needle Dia:
0.156" (3.96 mm)



DNN/6

Needle Length:
6" (150 mm)
Needle Dia:
0.156" (3.96 mm)



BULK LOADERS

BLV-02

9/16" (14.7 mm)



BLV-01

9 mm



BLV-06

1/2"



BLV-04

5/16"



AIR BLEEDER VALVES

ARV

Manual



SA-ARV

Automatic



All grease gun accessories are available in 1/8" BSPT, M10x1, 1/8" NPT threads.

BEARING PACKERS

BEP625

RAPID ACTION BENCH TYPE

Used with grease guns



BEARING	MIN	MAX
OUTER DIA	1/2" (12 mm)	6" (150 mm)
HEIGHT	3/8" (10 mm)	2" (50 mm)

BEP01

BEARING PACKER WITH THREADED CENTER POST

Used with grease guns



BEARING	MIN	MAX
OUTER DIA	1/2" (12 mm)	5" (125 mm)
HEIGHT	1/4" (6 mm)	2" (50 mm)

BEP10

HAND BEARING PACKER

SIMPLE HAND PRESS MECHANISM

Requires no Grease gun or pump to pack grease into bearings.



NEW!



Place bearing on piston
Maximum bearing dia. 3-1/2" (90mm)



Press the cap until the old grease is forced out and new grease shows on the bearing

BEARING	MIN	MAX
OUTER DIA	1-3/4" (45 mm)	3-1/2" (90 mm)



SCAN TO WATCH

GREASE FEEDERS

GFD-PP

Provides single point controlled lubrication for bearing housings. Eliminate difficulties due to over or under greasing



GFP-PA



GFD-PAN



GFD-BA



	GFD-PP	GFP-PA	GFD-PAN	GFD-BA
DOME	Polycarbonate	Polycarbonate	Polycarbonate	Tempered borosilicate with stainless steel cap
BASE	Nylon	Die Cast Aluminium	Die Cast Aluminium with Nickel Plating	Aluminium
TEMPERATURE	-23°C to 121°C (-10°F to 250°F)	-23°C to 121°C (-10°F to 250°F)	-23°C to 121°C (-10°F to 250°F)	-23°C to 232°C (-10°F to 450°F)
APPLICATION	Static Non Vibratory Conditions	Dynamic applications involving vibration & shocks	Corrosive environment: Dynamic applications involving vibrations & shock: chemical plants, food industry etc.	Very high temperature applications: nuclear plants, steel mills, lumber drying kilns etc.
BOWL CAPACITY	1 oz, 2 oz, 6 oz	1 oz, 2 oz, 6 oz	1 oz, 2 oz, 6 oz	4 oz

EASY OUT TOOLS

- Dual purpose tool for
 - Removing worn out grease fittings
 - Tap holes for installing grease fittings

ESO-1

For fittings with hex size — 5/8" & 3/8". Tap rethreads 1/4" - 28

ESO-2

For fittings with hex size 3/8" & 7/16" (11 mm) Tap rethreads 1/8" - 27

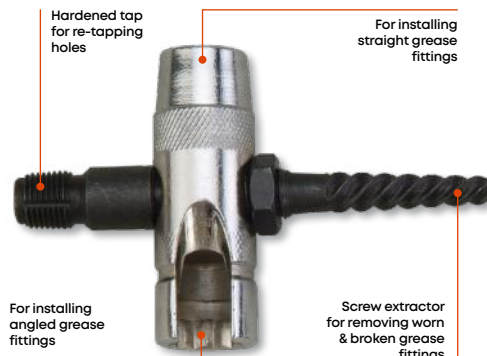

All grease gun accessories are available in 1/8" BSPT, M10x1, 1/8" NPT threads.

GREASE FITTINGS & ACCESSORIES

GREASE FITTINGS



6,000 PSI (413 BAR)

SAE J534 Heat Treated

IATF 16949 Approved Manufacturing

- Available in a range of raw material: EN-1A, steel, 303 stainless steel, brass monel etc.
- Steel fittings are zinc plated with a guaranteed salt spray life of over 72 hours
- Fitting profile & dimensions are accurately controlled & conform to SAE, DIN, BS, JIS & IS standards

STEEL FITTINGS - METRIC

6.0 x 1 mm
8.0 x 1 mm
8.0 x 1.25 mm
10.0 x 1 mm
10.0 x 1.5 mm

STEEL FITTINGS - SAE

1/4"-28 SAE-LT
1/8"-27 Pipe Threads
1/4" - 18 Pipe Threads

BSPT PIPE THREADS

1/8" x 28 BSPT
1/4" x 19 BSPT

PARALLEL THREADS

UNF
BSF

SELF FORMING THREADS

1/8" - 27
1/4" - 28

DRIVE FITTINGS

Drive Fittings

BUTTON HEAD FITTINGS

Parallel Threads
Taper Threads

STAINLESS STEEL

1/4" - 28 SAE-LT
1/8" - 27 Pipe Thread
1/8" - 18 Pipe Thread
1/8" x 28 BSPT Taper Thread
M6 x 1.0 mm
M8 x 1.0 mm
M10 x 1.0 mm



GREASE FITTINGS THREAD TESTER

THT



Designed to sort grease fittings with 21 most popular thread types:

THREAD TYPE	SIZE		
NPT	1/8"	1/4"	3/8"
METRIC	M6 x 1	M6 x 0.75	
METRIC	M8 x 1	M8 x 1.25	
METRIC	M10 x 1	M10 x 1.5	
BSPT	1/8"	1/4"	
UNF/ANF	1/4"	5/16"	3/8"
BSW	1/4"	5/16"	1/2"
BSF	3/16"	1/4"	5/16"

GREASE FITTINGS CAPS

CAP GFT

EXTRA LONG
Length: 1.69" (43 mm)



STANDARD
Length: 0.94" (24 mm)



'DRIVE FIT' GREASE FITTING INSTALLER

FTS/01

- For driving in straight fittings



FTA/01

- For driving in angled fittings



GREASE FITTINGS UNBLOCKER

GFU

- Useful tool to open clogged grease fittings and loosen hardened grease fittings
- To use: Tap with a hammer to force a light oil through the coupler into grease joint breaking up and removing dirt & debris



GREASING ADAPTORS & ELBOWS



6,000 PSI (413 BAR)

ADP

Used to adapt a threaded fitting to a different sized thread.
Available in straight, 45° and 90° configuration



GREASE FITTINGS SETS

GFT/KIT/SS/SAE-40

40 pcs - SAE
1/8"-27 PTF
1/4"-28 SAE-LT

Stainless steel



GFT/KIT/BSPT-50

50 pcs - BSPT
1/8"-28 BSPT
1/4"-19 BSPT



GFT/KIT/SAE-80

80 pcs - SAE
1/8"-27 PTF
1/4"-28 SAE-LT



GFT/GC/KIT/SAE-100

100 pcs - SAE
1/8"-27 PTF
1/4"-28 SAE-LT
Grease Fitting Caps



GFT/KIT/SAE-110

110 pcs - SAE
1/8"-27 PTF
1/4"-28 SAE-LT



GFT/KIT/M-44

44 pcs - METRIC
M6 x 1
M8 x 1
M10 x 1



GFT/KIT/M-80

80 pcs - METRIC
M6 x 1
M8 x 1
M10 x 1



GFT/ESO/KIT/M-101

101 pcs - METRIC
M6 x 1
M8 x 1
M10 x 1
Easy Out Tools



GFT/KIT/M-110

110 pcs - METRIC
M6 x 1
M8 x 1
M10 x 1



GFT/KIT/M-110A

110 pcs - METRIC
M6 x 1
M8 x 1
M10 x 1



KIT/GK/SAE-60

60 pcs - SAE
1/8"-27 PTF
1/4"-28 SAE-LT
HC/14 coupler
HC/12 coupler
HC/R coupler
DNN



KIT/GK/M-60

60 pcs - METRIC
M6 x 1
M8 x 1
M10 x 1
1/8"-27 PTF
1/4"-28 SAE-LT
HC/14 coupler
HC/12 coupler
HC/R coupler
DNN



GFT/KIT/ULT/SAE-65

65 pcs - SAE
1/8"-27 PTF
1/4"-28 SAE-LT
Easy Out Tools
Grease Fitting Caps
HC/14 coupler
THT



GFT/GC/KIT/M-100

100 pcs - METRIC
M6 x 1
M8 x 1
M10 x 1
Grease Fittings Caps



GFT/ESO/KIT/SAE-101

101 pcs - SAE
1/8"-27 PTF
1/4"-28 SAE-LT
Easy Out Tools



GFT/KIT/ULT/SM-65

65 pcs - SAE + METRIC
1/8"-27 PTF
1/4"-28 SAE-LT
M6 x 1
M8 x 1
Easy Out Tools
Grease Fitting Caps
HC/14 coupler
THT



GFT/KIT/UNBS/140

140 pcs - BSPT + UNF
1/4"-28 SAE-LT
5/16" - 24 UNF
1/8" - 28 BSPT



GFT/TW/ESO/KIT/SAE-194

194 pcs - SAE
1/8"-27 PTF
1/4"-28 SAE-LT
Easy Out Tools
Grease Fitting Caps



GFT/TW/ESO/KIT/SAE-134

134 pcs - SAE
1/8"-27 PTF
1/4"-28 SAE-LT
Easy Out Tools

QUICK CONNECT ADAPTORS
CONNECT OR DISCONNECT WITH A SNAP



1,000 PSI (69 BAR)

DNN/1-8/90/Q

Quick Connect
Right Angled
Needle Nose
Dispenser



6,000 PSI (413 BAR)

HC/14/4/90/Q

Quick Connect
Right Angled
Grease Coupler



1,000 PSI (69 BAR)

GIN/01/Q

Quick Connect
Grease Injector
Needle



1,000 PSI (69 BAR)

RLA-01

Recessed Lube
Adaptor



1,000 PSI (69 BAR)

ALA-01

90° Angled Lube
Adaptor



1,000 PSI (69 BAR)

ANN-4

Needle Nose
Adaptor

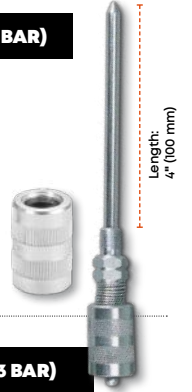

1,000 PSI (69 BAR)

AQD

Needle Nose
Adaptor



1,000 PSI (69 BAR)

ANN/1-1-2

Narrow Needle
Nose Adaptor



6,000 PSI (413 BAR)

GBP/6/HC/14/4/Q

Coupler
to Coupler
Extension



6,000 PSI (413 BAR)

HC/SW/3/Q

360° Swivel
Coupler



1,000 PSI (69 BAR)

SOD/01/Q

Jaw Type
Coupler to Seal
Off Dispenser



3,000 PSI (207 BAR)

POC-1Q

Jaw Type
Coupler to Button
Head Coupler



1,000 PSI (69 BAR)

HC/R/01/Q

Regular Coupler
to Right Angled
Coupler



3,500 PSI (241 BAR)

GHC/GIN/Q

Quick Connect
Grease Hose &
Needle



3,500 PSI (241 BAR)

GHC-12/SPR/W/ADP

Quick Connect
Hose



AQD/UF

Quick Disconnect
Adaptors



Supplied with a small &
large locking sleeve to fit
all couplers



5,000 PSI (345 BAR)

HC-90Q

Quick Connect
90° Compact
Coupler



NEW!

GREASE ACCESSORY KITS - QUICK CONNECT







EZEE LUBE KIT

GAK-7

- A range of quick connect lube accessories for effective lubrication.
- Constituents convert any grease gun fitted with jaw type coupler into special application greasing for effective lubrication of grease plugs, sealed bearings, push on greasing of recessed fittings or fittings in shoulders, low height areas or an extension for reaching those "deep" places



Kit Constituents

			
RLA/01 Recessed Lube Adaptor	GIN/01 1-1/2" x 18 gauge Grease Injector Needle	ALA/01 90° Angled Lube Adaptor	ANN/1-1-2 1-1/2" (38 mm) Narrow Needle Nose Adaptor
			
SOD/01/Q Seal Off Dispenser	HC/R/01/Q Right Angled Coupler	GHC-12/SPR/W/ADP 16" (400 mm) Hose	

GREASING ACCESSORY KIT PREMIUM

GAK-P

NEW!

- 8 of the most useful Greasing accessories that cover most greasing applications, packed in a top quality premium blow mould case



Kit Constituents

			
ALA/01 90° Angled Lube Adaptor	RLA/01 Recessed Lube Adaptor	ANN/1-1-2 1-1/2" (38 mm) Narrow Needle Nose Adaptor	HC/90/Q 90° Compact Coupler
			
GIN/01 1-1/2" x 18 gauge Grease Injector Needle	SWV/1-8M/1-8F Grease Gun Swivel (1/8" M x 1/8" F)	HC/21 Quick Lock Grease Coupler	GHC-12/SPR 12" (300 mm) Grease Hose with Spring

GREASING ACCESSORY KIT STANDARD

GAK-E

- Greasing kits with 11 of the most popular accessories packed in a top quality premium blow mould case



Kit Constituents

					
ANN/4 4" (100mm) Needle Nose Adaptor	DNN/1-1-2/GFT 1-1/2" (38 mm) Narrow Needle Nose Dispenser	DNN/1-8/GFT 19/32" (15 mm) Needle Nose Dispenser	HC/R/01/GFT 90° Hydraulic Coupler	GIN/01 1-1/2" x 18 gauge Grease Injector Needle	
					GHC-12 12" (300 mm) Grease Hose
SOD/01/GFT Seal Off Dispenser	HC/11/4 4 Jaw Standard Hydraulic Coupler	HC/SW/11/4 360° Slim Line Swivel Coupler	GSP/4 4" (100 mm) Steel Extension	GBP/6 6" (150 mm) Steel Extension	

NEW!

GREASE PUMPS & ACCESSORIES

AIR OPERATED GREASE RATIO PUMP 50:1



1.10 kg/minute

GP0

Fits 12.5 kg drums

GP1 & GP4

Fits 20-30 kg/25-50 lbs pails

GP2

Fits 50-60 kg/120 lbs pails

GP3

Fits 180 kg / 400 lbs drums

BGRP

Bucket Capacity: 15 kg, 30 kg, 50 kg

- Pump dispenses grease at pressures upto 50 times the air inlet pressure
- Max. Outlet Pressure: 7,500 PSI
- Max. Air Pressure: 150 PSI/10 BAR
- Air Motor: 2-1/2" (63 mm)



GP



BGRP

GREASE CONTROL VALVES



7,500 PSI (517 BAR)

- Available with & without Z swivels

APG-04

Steel body

APG-HD

Heavy Duty Steel body



GREASE CONTROL VALVE BOOSTER



10,000 PSI (690 BAR)

- Built in pressure boost mechanism
- Available with & without Z swivels

APG

Steel Body

APG-PR

Steel Body with pressure release valve

APG-NS

Aluminium Body



AIR OPERATED GREASE RATIO PUMP 60:1



1.10 kg/minute

GP1-601

Fits 20-30 kg/25-50 lbs pails

GP2-601

Fits 50-60 kg/120 lbs pails

GP3-601

Fits 180 kg/400 lbs drums

- Pump dispenses grease at pressures upto 60 times the air inlet pressure
- Maximum Outlet Pressure: 9,000 PSI (620 BAR)
- Max. Air Pressure: 150 PSI/10 BAR
- Air Motor: 2-3/4" (70 mm)

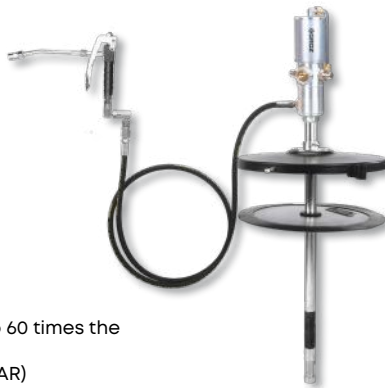

HIGH VOLUME GREASE RATIO PUMPS 50:1



3.40 kg/minute

GPH1

Fits 20-30 kg/25-50 lbs pails

GPH2

Fits 50-60 kg/120 lbs pails

GPH3

For 180 kg/400 lbs drums

- Stall free, ice free motor
- Air motor : 3" (76 mm)
- Working Pressure: 30-150 PSI (2-10 BAR)
- Max Outlet Pressure: 7,500 PSI (500 BAR)



GREASE CONTROL VALVE METERED



7,500 PSI (517 BAR)

APG-GM

- Digital Oval Gear Meter
- Measures in kg & lbs
- Grease flow: 0.1-2.5 kg/minute (0.2-5.5 lbs/minute)



HIGH PRESSURE GREASE SWIVELS



6,000 PSI (413 BAR)

HFC-Z

360° unrestricted, 3 axes movement



HFC-R

90°, 2 axes movement



HFC-S

Single axis swivelling



PORTABLE GREASING SYSTEM

GS-5

- Foot Charged: Single foot press provides upto 30 shots of grease
- Bucket Capacity: 5 kg



SCAN TO WATCH



SETTING	PRESSURE	DELIVERS	APPLICATION
High Pressure	10,000 PSI	0.45 gm/stroke	Cold weather, blocked fittings
High Volume	-	1.25 gm/stroke	Volume greasing

BUCKET GREASERS

VGP

- For quick & effortless greasing in applications requiring bulk and frequent greasing

VARIABLE HANDLE SETTING

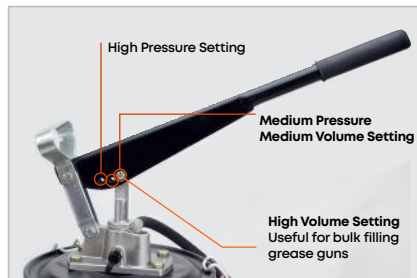

SETTING	PRESSURE	DELIVERS
High Pressure	4,000 PSI	4 gm/stroke
Medium Pressure	3,000 PSI	7 gm/stroke
High Volume	2,000 PSI	9 gm/stroke

WITHOUT WHEELS

3 KG	6 KG
10 KG	15 KG



WITH WHEELS

6 KG	10 KG
15 KG	20 KG
30 KG	



GREASE FILLER PUMP



UPTO 28GM/STROKE

- Simple solution to load grease guns from grease pails
- Suitable for use with upto NLGI-2 grease

GFP-02

Fits 12.5 kg pails

GFP-03

Fits 35 lbs (20-30 kg) pails



GFP-04

Fits 120 lbs (50-60 kg) pails

HIGH PRESSURE GREASE PUMP



3,500 PSI (240 BAR)

GFP-HP

- For high pressure greasing where airline connection and power are not available

GFP/HP-02

Fits 12.5 kg pails

GFP/HP-03

Fits 20 kg (25-50 lb) pails



FOOT OPERATED BUCKET GREASE PUMP



8,700 PSI (600 BAR)

- Hands-free, Fatigue-free greasing solution
- Delivers: Upto 2 gm/stroke
- Bucket Capacity: 10 kg



FOP-10A

FOP-10Q

With quick lock coupler

FEMALE LOADER ADAPTORS

ADP/9147

Used with 9mm straight & American tapered 0.58" Bulk loader valve



SFA/1-4/N

Used with American tapered 0.58" Bulk loader valve



FOLLOWER PLATES

FLP

Rubber Lined follower plates



Follower plate for suction filling grease guns



All steel Follower plates



SCOOP & SWIPE SET

GSW



STEP 1
Use the Scooper to draw sizable amount of grease from the bucket

STEP 2
Use the swipe to clean the Scoop from inside

STEP 3
Use the swipe to clean the Scoop from outside



SCAN TO WATCH

TROLLEY MOUNTED KITS - GREASE

GREASE PUMP KITS

- Ideal for use in workshops & shop floors providing complete portability for everyday lubrication needs
- Grease Output: 1.1kg/minute (2.42 lbs/minute)



7,500 PSI (500 BAR)

TMK-GP1

For 20-30 kg
(35 lbs) drums



TMK-GP2

For 50-60 kg
(120 lbs) drums



TMK-GP3H

For 180 kg
(400 lbs) drums



TMK1-GP3

For 180 kg
(400 lbs) drums



TMK1-GP3H

For 180 kg
(400 lbs) drums



TMK2-GP1

For 20-30 kg
(35 lbs) drums



TMK2-GP2

For 50-60 kg
(120 lbs) drums



02 oiling

OIL PUMPS - MANUAL

LEVER ACTION OIL PUMPS



UPTO 300ML (10 OZ.) / STROKE

- Most popular Lever Action Pumps complete with telescopic suction tube for use with 50-205 litre (15-50 gallon) drums
- Built in 1-1/2" & 2" bung
- Use with: Oils, Oil Based Fuels, Diesel & Kerosene

LBP04

- Powder coated steel barrel
- Zinc die-cast piston
- Brass piston rings
- NBR seals
- Steel suction tube



LBP04-CL

- Polycarbonate clear tube barrel with steel piston
- NBR piston rings & seals
- Steel suction tube
- Clear tube provides visibility to fluid contamination



EBP02

- Steel body
- NBR piston rings
- PVC suction tube



LEVER ACTION ANTIFREEZE PUMPS



UPTO 300 ML (10 OZ.) / STROKE

- Lever Action Pumps complete with telescopic pipe for use with 50-205 litre (15-50 gallon) drums
- Built in 1-1/2" & 2" bung
- Use with 100% Antifreeze, Thinners, Chemicals, Oil Based Media & Automotive additives

LBP06

- Powder coated steel body
- Zinc die-cast piston
- Brass piston rings
- Viton seal
- Steel suction tube



LBP96

- Powder coated steel body
- Zinc die cast piston
- Brass piston rings
- Viton seal
- Complete with non drip & bucket hanger
- Steel suction tube



VERTICAL LIFT PUMP



UPTO 750ML (26 OZ. /STROKE)

VLP01

- Self priming high volume pump
- Aluminum die cast head, steel plunger rod & PTFE seals
- For use on 205 litres (55 gallon) drums
- Use with High viscosity petroleum media, Lacquer Thinners etc.



STEEL SAFETY PUMP



UPTO 165 ML (5.5 OZ.) /STROKE

VLP-5

Fits 20-30 litre (5 gallon) pails



- For use with combustible & flammable media
- Carbon Steel pump body with PTFE piston & sealing gasket
- Bonding & grounding wires prevent hazardous static charge
- In built flame arrestor

- Use with Gasoline, Diesel, Kerosene, Lacquer, Thinners, Acetone, Benzene, Naptha, Urea etc.

VLP-55

Fits 205 litre (55 gallon) drums



FRONT ACTION DRUM PUMP



UPTO 250 ML (9 OZ.) / STROKE

A2

- Low height design with pump submerged in container for ease in operation
- Variable handle setting for use with light or heavy fluids
- Complete with delivery hose & nozzle
- For use on 205 litres (55 gallon) drums
- Use with Oils, Diesel, Kerosene etc.



ROTARY DRUM PUMPS



UPTO 250 ML (9 OZ.) / ROTATION

GNB-25

- Cast iron pump body with machined vanes
- Pump Weight: 6.6 kg (14.5 lbs)
- For use with 50-205 litres (15-55 gallon) drums
- Use with Diesel, Kerosene & Oils

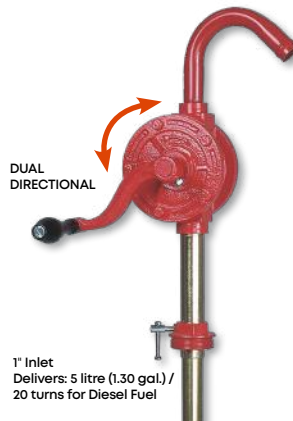

ROTARY DRUM PUMP PROFESSIONAL



UPTO 200 ML (7 OZ.) / ROTATION

RB1

- Aluminum Die Cast pump with zinc die cast rotor & vanes
- Horizontal outlet for installing filter/meter
- For use on 50-205 litres (15-55 gallon) drums
- Use with Gasoline, Diesel, Kerosene Lubricating Oils upto SAE60 & 100% Antifreeze



QUART / LITRE STROKE PUMP



1 LITRE (1 QUART) / STROKE

QSP

- Heavy duty pump dispenses exactly 1 litre or 1 quart per stroke
- Works on a Precision Rack & Pinion Mechanism
- Pump complete with
 1. Spring loaded drain back tube
 2. Lockable handle
 3. 2" bung adaptor with lock nut
 4. Telescopic suction tube for use on 50-205 litre (15-55 gal.) drums
- Use with Gear & Lube Oil, Diesel, Kerosene & Petroleum based media



EZEE FLO PUMP



UPTO 1 L / 18 STROKES

EZF-DS

- Designed for use on 20-25 litre / 5 gallon containers with plastic pull out (Rieke® spout) or 2" external threads
- Polyethylene head with nozzle holder
- Pump length can be extended upto 4"
- 7 adaptors for use with most metal & plastic containers
- Complete with 48" long spring embedded hose fitted with steel spout with non drip
- Use with Light Oils, Diesel, Antifreeze & Glycerine

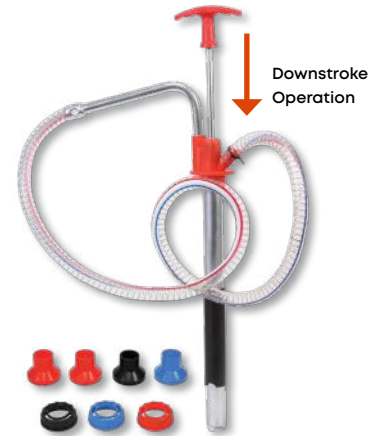

OIL LUBE DISPENSERS

- Designed for transferring transmission differentials & heavier oils
- Aluminium die cast head & adjustable flange

BLP

- Pump with steel drum cover & 4' (48") PVC hose with nozzle
- **Delivers: 60 ml (2.14 oz.) / stroke**
- Available in two sizes: For use with 5 gal. & 16 gal. oil pails



OLP

- Pump with inbuilt steel bucket
- **Delivers: 100 ml (3.4 oz.) / stroke**
- Available in 3 sizes: 12, 16, & 30 litre with & without wheels



SPRING LOADED PUMP



UPTO 500 ML / CHARGE

SLP

- Spring Loaded Mechanism: Pressing down the pump handle charges the pump for continuous flow
- Complete with 5' long spring embedded hose with control gun
- For use on 60 litre drums popular in Australia & New Zealand
- Use with Engine & Gear Oils upto SAE 140 and ATF



EZEE FLO PUMP PREMIUM



UPTO 0.9 L / 14 STROKES

EZF-PR

- Designed for use on 20-25 litre / 5 gallon containers with 2" bung
- **Downstroke Operation**
- High density polyethylene head with nozzle holder & drum filler plug
- Pump length can be extended upto 4"
- Complete with 48" long spring embedded hose fitted with steel spout with non drip
- Use with Light Oils, Diesel, Antifreeze & Glycerine



DRIP PANS

DP

- Fits onto any 2" threaded opening on drum, barrel or tank
- Useful for returning over flown media back into drum & also acts as a base for holding containers

CAST IRON BODY

For use with pumps with suction tube dia. upto 33.5 mm



CAST ALUMINIUM BODY

Works with any pump with 2" bung



SUCTION TUBES

- Suction tubes, for use with all types of drum pumps
- Available in Telescopic or Rigid style in different length & threads

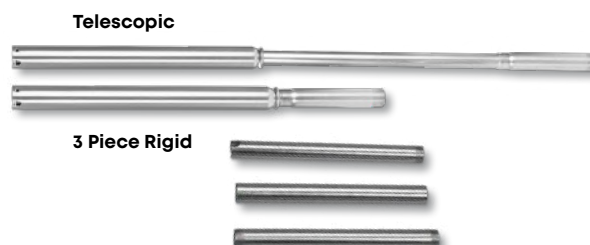

BUNG NUTS

- Cast iron bung nuts / adaptors for use on 2" drums



AIR OPERATED OIL PUMPS & ACCESSORIES

RATIO PUMP

- All metal fully CNC machined construction
- 2-1/2" (63 mm) dia. air motor
- Pump Outlet: 1/2" BSP (F) or 1/2" NPT (F)
- Available in stub version or with suction tube suitable for 50-60 litre drums & 205 litre drums
- All pumps supplied with bung adaptor

OP11

1:1
Low to Medium viscosity oils upto SAE 80 for transfer over distances upto 5 meters

Delivers:
Upto 40 LPM
(10.5 GPM)



Double Acting

OP31

3:1
Medium to High viscosity oils (upto SAE 130) for transfer over distances upto 30 meters

Delivers:
Upto 14 LPM
(3.70 GPM)



OP51

5:1
High viscosity oils (upto SAE 240) for transfer over long distances upto 50 meters

Delivers:
Upto 18 LPM
(4.76 GPM)



Double Acting

RATIO PUMP STAINLESS STEEL - 3:1



UPTO 14 LPM (3.7 GPM)

OPSS

- **Stainless steel pump for use with water based Fluids, Coolants, Detergents, Water etc.**
- Working Pressure: 30-150 PSI (2-10 BAR)
- Complete with suction tube and 2" bung for use with 205 litre (55 gallon) drums



AIR OPERATED TRANSFER PUMP

NEW!



UPTO 45 LPM (12 GPM)

ATP

- Pump complete with:
 1. Pre-set Air Pressure Regulator: factory set at 5 PSI (0.3 BAR)
 2. 1/4" spring loaded safety valve prevents excessive pressure build-up
 3. 2 pc suction tube for use on 50-205 litre (15-50 gallon) drums
 4. 6' x Ø1" (25 mm) discharge hose & spout
- Use with: Diesel, Kerosene, Oil, Water & Corrosive media
- Available with steel or SS suction tubes



WARNING

Pump must be supplied with clean & dry compressed air.
The standard pump configuration is also not suitable for use with flammable media such as Gasoline.
For the pump to operate, drum must be sealed ensuring no air outlet to maintain pressure.

OIL PUMP 6.5:1



UPTO 18 LPM (4.76 GPM)

OPH

- Industrial Grade Pneumatic Pump
- **3" (76 mm) dia Stall & Ice free motor**
- Pump Outlet: 1/2" NPT (F) or 1/2" BSP (F)
- Stub pump with 2 additional suction tubes
- Ideal for use with oils upto SAE 240 for transfer over long distances (60 metres)



MOUNTING BRACKET

- For installing pumps
- 2" (F) threaded bung



FOOT VALVE

- Aluminium construction
- Used as a non return valve at the bottom of a suction tube
- Sizes: 3/4" & 1"



BUNG NUT

- 2" Drum Bungs
- Sizes available:
ID 30mm
36mm
42mm



HYDRAULIC HOSES

- Rubber Hoses (SAE 100 R1) for use with Air Operated Oil Pumps
- Crimped with steel fittings with 1/2"(M) threads on both ends
- Working Pressure: 2,200 PSI (150 BAR)



TROLLEY MOUNTED KITS - OIL

OIL PUMP KITS

- Ideal for use in workshops & shop floors providing complete portability for everyday lubrication needs
- Available in choice of NPT & BSPT thread

NEW!

TMK-OP3

For 205 litre (55 gal.) drums



TMK-OP3H

For 205 litre (55 gal.) drums



TMK-OP5H

For 205 litre (55 gal.) drums



TMK-OPH

For 205 litre (55 gal.) drums



TMK1-OP3

For 205 litre (55 gal.) drums



TMK1-OP3H

For 205 litre (55 gal.) drums



TMK1-OP5

For 205 litre (55 gal.) drums



TMK1-OP5H

For 205 litre (55 gal.) drums



TMK2-OP3

For 50-60 litre (16 gal.) drums



TMK2-OP5

For 50-60 litre (16 gal.) drums



OIL PUMPS - ELECTRIC

ELECTRIC OIL DRUM PUMP



UPTO 16 LPM (4.2 GPM)

EDR-OL

- Compact & lightweight AC Powered: 100V -240V, 50/60 Hz
- Suitable for use on 205 litres (55 gal.) drums or 1000-1250 litres (275-330 gal.) IBC's /Totes
- **Duty Cycle:** 15 Minute ON / 30 Minutes OFF
- Use with Motor Oil, Hydraulic Oil & Lubricants



Electric Oil Pump



Electric Oil Pump- Metered



SCAN TO WATCH

ELECTRIC OIL PUMPS

- Self priming, geared pump
- Ideal for use with oils upto SAE 90
- **Duty Cycle: 30 Minute ON / 30 Minutes OFF**
- Available in AC & DC versions

OPM-HF

AC High Flow

115V
30 LPM (8 GPM)
220V
23 LPM (6 GPM)



AC

OPM

AC Regular Flow

115V
15 LPM (4 GPM)
220V
11.5 LPM (3 GPM)

DC Regular Flow

12V
13.2 LPM (3.5 GPM)



DC

DOUBLE DIAPHRAGM PUMPS

AODD

- Designed for applications requiring large volume transfer in a very short time
- Self Priming: High suction lift even at dry start up
- Ability to run dry: No close fittings or sliding parts at risk
- Explosion proof: Used with compressed air these are safe pumps
- Submersible: Pump can be submerged in liquid by running exhaust line above liquid level



AODD/1-4/FPT/N

Size: 1/4"

Polypropylene Casing

PTFE Diaphragm

Flow Rate: 0 - 11 LPM (0 - 2.90 GPM)

For use with:
Windshield washer fluid, Antifreeze, Caustic soda, Sulfuric acid (up to 75%), Plating Solution, Photograph developing liquid, Benzene, Hydrogen Peroxide, Waste water etc.



AODD/1-2/BAH/N

Size: 1/2"

Aluminium Casing

Hytre^l Diaphragm

Flow Rate: 0 - 50 LPM (0 - 13.22 GPM)

For use with:
Diesel fuel, Kerosene, Lubricants, Gear oil, Engine oil, Waste oil, Brake fluid, Naphtha, Mold lubricants, Antifreeze and Waste water



AODD/1-2/FPT/N

Size: 1/2"

Polypropylene Casing

PTFE Diaphragm

Flow Rate: 0 - 45 LPM (0 - 11.90 GPM)

For use with:
Windshield washer fluid, Antifreeze, Caustic soda, Sulfuric acid (up to 75%), Plating Solution, Photograph developing liquid, Benzene, Hydrogen Peroxide, Waste water etc.



AODD/1-2/FPS/N

Size: 1/2"

Polypropylene Casing

Santoprene[®] Diaphragm

Flow Rate: 0 - 45 LPM (0 - 11.90 GPM)

For use with:
DEF, Antifreeze, Ethanol, Ammonium hydroxide and Waste water



AODD/3-4/BAH/N

Size: 3/4"

Aluminium Casing

Hytre^l Diaphragm

Flow Rate: 0 - 110 LPM (0 - 29.1 GPM)

For use with:
Diesel fuel, Kerosene, Lubricants, Gear oil, Engine oil, Waste oil, Brake fluid, Naphtha, Mold lubricants, Antifreeze and Waste water



AODD/3-4/BPS/N

Size: 3/4"

Polypropylene Casing

Santoprene[®] Diaphragm

Flow Rate: 0 - 110 LPM (0 - 29.1 GPM)

For use with:
DEF, Antifreeze, Ethanol, Ammonium hydroxide and Waste water



AODD/0-1/BAH/N

Size: 1"

Aluminium Casing

Hytre^l Diaphragm

Flow Rate: 0 - 110 LPM (0 - 29.1 GPM)

For use with:
Diesel fuel, Kerosene, Lubricants, Gear oil, Engine oil, Waste oil, Brake fluid, Naphtha, Mold lubricants, Antifreeze and Waste water

OIL METERS, NOZZLES & ACCESSORIES

ELECTRONIC OIL METER - HEAVY DUTY



1-30 LPM (0.3-8 GPM)

OM200

- **Oval Gear Mechanism for optimum accuracy**
- Accuracy: $\pm 0.50\%$
- Meter Inlet / Outlet threaded: 1/2" (F)
- Measures in litres, gallons, quarts, pints, ounces & decilitres
- For use with Oils upto SAE 140, Diesel, Kerosene & Engine Coolants (RTU)



ELECTRONIC OIL METER - PROFESSIONAL



1-30 LPM (0.3-8 GPM)

OM2000

- **Oval Gear Mechanism for optimum accuracy**
- Accuracy: $\pm 0.50\%$
- Meter Inlet / Outlet threaded 1/2" (F)
- Measures in litres, gallons quarts & pints
- For use with Oils upto SAE 140



MECHANICAL OIL METER



1-30 LPM (0.3-8 GPM)

OM10

- **Oval Gear Mechanism for optimum accuracy**
- Accuracy: $\pm 1\%$
- Meter Inlet / Outlet threaded 1/2" (F)
- Measures in litres & quarts
- For use with Oils with viscosity upto 2000 cSt, Diesel, Biodiesel



OIL CONTROL GUN - MANUAL



1 - 30 LPM (0.3 - 8 GPM)

OGN

- Aluminium die cast construction
- Built-in continuous flow switch
- Inlet Threads: 1/2" (F)
- For use with oils with viscosity upto SAE 140



Steel Extension



Steel Extension & Manual Non Drip Nozzle



Steel Extension & Automatic Non Drip Nozzle



Hose & Manual Non Drip Nozzle



Hose & Automatic Non Drip Nozzle



Hose Extension With Bent Steel Pipe & Manual Non Drip Nozzle



Hose Extension with Bent Steel Pipe & Automatic Non Drip Nozzle

HEAVY DUTY ELECTRONIC OIL CONTROL GUNS



1 - 30 LPM (0.3 - 8 GPM)

OGN-OM200

- Aluminium die cast Oil Control Gun with Oval Gear Digital Meter (OM-200)



With Steel Extension & Manual Non Drip Nozzle



With Steel Extension & Automatic Non Drip Nozzle



With Hose & Manual Non Drip Nozzle



With Hose & Automatic Non Drip Nozzle



With Hose Extension, Bent Steel Pipe & Manual Non Drip Nozzle



With Hose Extension, Bent Steel Pipe & Automatic Non Drip Nozzle

PROFESSIONAL ELECTRONIC OIL CONTROL GUNS



1 - 30 LPM (0.3 - 8 GPM)

OGN-OM2000

- Aluminium die cast Oil Control Gun with Oval Gear Digital Meter (OM-2000)



With Steel Extension & Manual Non Drip Nozzle



With Steel Extension & Automatic Non Drip Nozzle



With Hose & Manual Non Drip Nozzle



With Hose & Automatic Non Drip Nozzle



With Hose Extension, Bent Steel Pipe & Manual Non Drip Nozzle



With Hose Extension, Bent Steel Pipe & Automatic Non Drip Nozzle

MECHANICAL OIL CONTROL GUNS

NEW!



1 - 30 LPM (0.3 - 8 GPM)

OGN-OM10

- Aluminium die cast Oil Control Gun with Mechanical Meter (OM-10)
- Max working pressure: 1,000 PSI (70 BAR)



With Steel Extension & Manual Non Drip Nozzle



With Steel Extension & Automatic Non Drip Nozzle



With Hose & Manual Non Drip Nozzle



With Hose & Automatic Non Drip Nozzle



With Hose Extension, Bent Steel Pipe & Manual Non Drip Nozzle



With Hose Extension, Bent Steel Pipe & Automatic Non Drip Nozzle

ELECTRONIC PRESET OIL CONTROL GUN



1 - 30 LPM (0.3 - 8 GPM)

OM300

- Dual Mode - Manual & Pre-set (dispenses set quantity of media and stops)
- **Oval Gear Mechanism for optimum accuracy**
- Accuracy: $\pm 0.50\%$
- Measures in litres, quarts, pints, gallons
- Use with Oils with viscosity upto 5000cst, Diesel & Biodiesel



SUCTION GUNS

- Designed for use with gear oils to get them both into and out of gear boxes, transfer cases and differentials
- Suitable for use with non corrosive liquids

SG10

Aluminium Die Cast Head

Capacity: 500 ml (16oz.)



SG10-CL

Clear tube helps identify fluid contamination

Capacity 400 ml (14 oz.)



SG11

Plated steel head

Capacity: 500 ml (16 oz.)



Capacity: 700 ml (24 oz.)



Capacity: 1000 ml (32 oz.)



TRANSFER GUNS

- Dual Action Gun: Draws in & pumps out liquid in a single stroke
- Safe solution for transferring media unsafe for human contact
- With 8' of vinyl hose (4' with each valve)

SG20

Aluminium barrel with aluminium die cast head

Capacity 350 ml / 12 oz.

Use with: Oils, Antifreeze, water etc.



SG21

Steel barrel with aluminium die cast head

Capacity 500 ml / 16 oz.

Use with: Oils & Spirits



SG21-CL

Clear Tube Barrel helps identify fluid contamination

Capacity: 450ml (15 oz)

Use with: Oils, Non-corrosive liquids, spirits & coolants

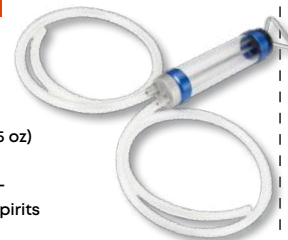

SCAN TO WATCH

OIL GUN HOSE EXTENSION



2,320 PSI (160 BAR)

HOS

- Flexible oil hose extension for use with oil control guns
- Length: 14" (350 mm)
- Hose Inner Dia: 1/2" (12.7 mm)
- Fittings: 1/2" (M) x 1/4" (M)



NON DRIP NOZZLES

NDN

Automatic Non Drip Nozzle: Inlet 1/4" (F)



Automatic Non Drip Tip: Inlet 9/16"-18 UNF



Manual Non Drip Nozzle: Inlet 1/4" (F)



OIL METER SWIVEL



2,320 PSI (160 BAR)

SWV

- Swivel Adaptor for Oil Meters / Hose End Guns
- Threaded: 1/2" (M) x 1/2" (F)



OIL SPIGOTS



800 PSI (55 BAR)

- Spigots are used as a dispenser with air operated pumps and also to construct Oil Bars
- Spring loaded dispensing mechanism

OBT-01

Steel Body With wall mount

OBT-02

Steel Body Without wall mount

OBT-03

Steel Body Non-locking style Nitrile Seal

OBT-03WF

Aluminium Body Non-locking style Viton Seal



SMART FUNNELS

- Polypropylene construction
- Anti-splash & spill proof
- With wire mesh screen, dust cover & flexible spout

FNL-8

Capacity:
1.7 Litre (1.7 Qt.)



FNL-9

Capacity:
3.0 Litre (3 Qt.)



FNL-9B

Capacity:
3.0 Litre (3 Qt.)
Complete with
2" bung for
attachment on
drum



FLEXIBLE SPOUT MEASURES

MSR

- High density polyethylene construction
- Available Capacity:

1	2	3
5	6	8

LITRE/QUART



UNIVERSAL OIL FUNNEL

FNL-UV

- Universal funnel with unique & innovative design: spring loaded, glass filled plier is adjustable for openings from 1"(25 mm) upto 3-1/8"(80 mm)
- No Spill, No Mess, Hands Free



Funnel with seal piercing filter

SETTING THE FUNNEL



Thread funnel into the clamp ring

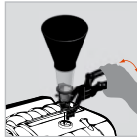

Start refilling the fluid into the engine



SCAN TO WATCH

SQUEEZE BOTTLE OIL CANS

SQZ

NEW!

- Low density polyethylene translucent body
- Available Capacity:

4	8	16	32
---	---	----	----

OUNCE



CONICAL FUNNELS

Polypropylene construction

FNL-6

Size: 650 ml



FNL-7

Size: 1800 ml



FUEL & OIL FUNNEL

FNL-11

- High flow fuel & oil funnel with large mouth for easy pouring
- Polypropylene construction
- Capacity:
4.7 litre /1.2 gallon



MEASURING JUGS

NEW!

JUG

- Heavy duty clear and transparent polypropylene body
- Available capacity:

3	8	20	32	64	160
---	---	----	----	----	-----

OUNCE



PLASTIC FUNNEL SET 4 PCS.

FNL-ST

Polypropylene construction



Capacity
430ml (15 oz.)



Capacity
245ml (8.5 oz.)



Capacity
120ml (4.20 oz.)



Capacity
40ml (1.40 oz.)

MEASURING FUNNEL

MFNL

- Funnel & measure built into one
- Funnel with graduations used to transfer measured quantity of fluid
- Capacity: 2 litre / 2 Quart & 5 litre / 5 Quart



SCAN TO WATCH



Funnel only



Funnel with Base



Funnel with Base and Dust Cap

PRECISION OILER

NEW!

POL-5

- Designed to lubricate the smallest, narrowest and hardest to reach places
- Solid Aluminium body with steel needle
- Useful in Automotive, Model making, Engineering, Watch and Jewellery making, Repair shops, DIY applications around the home



OIL CANS

- Body seamless drawn from tin coated sheet
- Choice of Steel & Brass pump with rigid or flexible spout; spouts available as spare

PT SERIES

125 ml
180 ml



200 ml
300 ml
400 ml
500 ml
700 ml
1000 ml

OC SERIES

Now available with corrugated flex steel spout

500 ml
1000 ml



180 ml
500 ml

03 waste oil

PUMPS & DRAINS

ELECTRIC WASTE OIL PUMP

- Self priming ZAMAC body with flexible impeller design for pumping high viscosity fluids at high flow rate
- **Duty Cycle: 45 Min ON/ 45 Min OFF**
- USE with: Used Oil, Engine Oil, Transmission Oil, Hydraulic Oil, Water, Ethylene Glycol

Empties
68 litres
in
3 min



AC Regular Flow

EWOP/115/US

115V
60 HZ
23 LPM (6 GPM)

EWOP/220/EU

220V
50 HZ
23 LPM (6 GPM)

DC Regular Flow

EWOP/12

12V
17 LPM (4.5 GPM)



WASTE OIL DRAIN - PRESSURISED

WOD-68

- Suitable for draining of motor, engine, gearbox & differential oils, transmission & power steering fluids
- Tank includes a pre-set air regulator for use with compressed air upto 150 PSI (10 BAR)
- Adjustable Bowl
- Tank Capacity: 68 litres / 18 gallons



AIR OPERATED DOUBLE DIAPHRAGM PUMPS - V SERIES

AODD-25-BAH

- Size: 1"
- Casing: Aluminium
- Diaphragm: Hytrel
- Flow Rate: Upto 140 LPM (37 GPM)
- Recommended Use: Diesel fuel, Kerosene, Lubricants, Gear oil, Engine oil, Waste oil, Brake fluid, Naphtha, Mold lubricants, Antifreeze & Waste water



AODD-15-BAH

- Size: 1/2"
- Casing: Aluminium
- Diaphragm: Hytrel
- Flow Rate: Upto 58 LPM (15.3 GPM)
- Recommended Use: Diesel fuel, Kerosene, Lubricants, Gear oil, Engine oil, Waste oil, Brake fluid, Naphtha, Mold lubricants, Antifreeze & Waste water



AODD-15-BPS

- Size: 1/2"
- Casing: Polypropylene
- Diaphragm: Santoprene
- Flow Rate: Upto 55 LPM (14.5 GPM)
- Recommended Use: Antifreeze, Ethanol, Ammonium Hydroxide & Waste Water



LOW PROFILE TRUCK DRAINS

TD68

TD90



Gravity Drain

- Rugged steel construction for heavy duty workshop use
- Use with: Diesel, Kerosene, Lubrication Oils, Non-corrosive media, Waste Fluids, Motor Oil, Transmission Fluids, Coolants etc
- Available in 2 sizes:
 - a. 68 litres (18 gallons)
 - b. 90 litres (23.7 gallons)

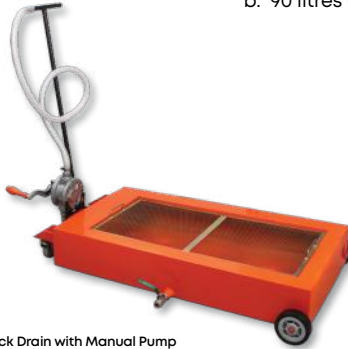

- Truck Drain with Manual Pump
- Pump Flow Rate: 1 Litre (0.25 gal) / 5 strokes



- Truck Drain with a choice of Electric Pumps
- 12V DC, 115V AC or 220V AC Electric Pumps
- Pump Flow Rate: Up to 23 LPM (6 GPM)

PLASTIC DRAINS

TD17

Capacity:
65 litres (17 Gallons)



Gravity Drain



- Truck Drain with Manual Pump
- Pump Flow Rate: 1 Litre (0.25 gal) / 5 strokes



- Truck Drain with a choice of 12V DC, 115V AC or 220V AC Electric Pumps
- Pump Flow Rate: Up to 23 LPM (6 GPM)
- Use with: Diesel, Kerosene, Lubricating oils (upto SAE 90), Non Corrosive Media, Waste Motor oil, Transmission Fluids, Coolants etc.



SCAN TO WATCH

DRAIN PANS

- High density polyethylene construction
- Capacity: 16 litres (4-1/4 Gallon)

ODP-16

- For use with waste oil



ODP-16GN

- For use with Antifreeze



DRAIN CONTAINER

ODP-15

- Capacity: 14.25 litres (15 Quarts)
- For use with Oil, Gasoline & Antifreeze



WASTE OIL EVACUATION KITS

KIT-AODD

- Suitable for use in workshops & garages for removing used oil from drains & delivery into oil sump tanks

	SIZE - 1/2"	SIZE - 1"
Flow Rate	0-50 LPM	0-110 LPM
Casing	Aluminium	Aluminium
Diaphragm	Hytrel	Hytrel
Max. Particle Size	1/32" (1 mm)	1/16" (2 mm)

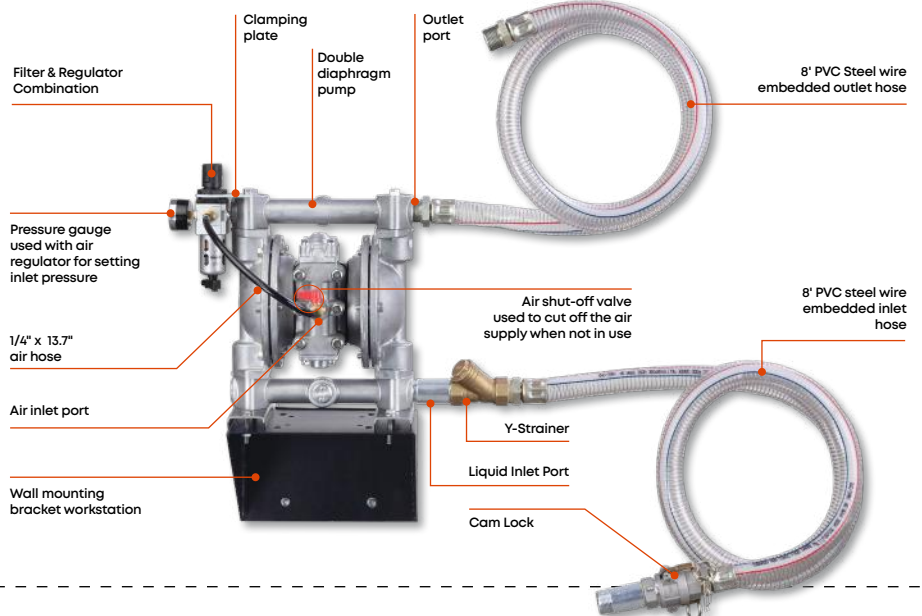

04 hose reels

HOSE REELS

- All metal hose reels
- **Casseted Spring Design:** for protecting the spring against corrosion and increased safety during repairs
- **Multiple Position Guide Arm:** for floor, wall or truck mounting option
- Accessories for floor mounting & angular mounting available
- Floor mounting bracket & wall mounting bracket also available

HR-AW

Air/Water

Low Pressure
Hose Reels

Max. Pressure
Upto 300 PSI (21 BAR)

Single Arm

Available in a choice of:
Inlet Threads:
3/8" or 1/2"

Hose Length:
10 m or 15 m



HR-OL

Oil

Medium Pressure
Hose Reel

Max. Pressure
Upto 2,000 PSI (138 BAR)

Dual Arm

Available in a choice of:
Inlet Threads:
3/8" or 1/2"

Hose Length:
10 m or 15 m



HR-GR

Grease

High Pressure
Hose Reel

Max. Pressure
Upto 5,800 PSI (400 BAR)

Dual Arm

Available in a choice of:
Inlet Threads:
1/4" or 3/8"

Hose Length:
10 m or 15 m



HOSE REEL E-SERIES

- All metal hose reels
- Auto retractable design for ease of use
- Weather-resistant enclosed design
- Rubber-enforced Hose – stays flexible in cold conditions
- Available in 3/8" & 1/2" Inlet thread
- Hose length: 10 & 15 m



NEW!

We also make plastic
hose reels. Check out
details on page no. 45

05 fuel

FUEL PUMPS - MANUAL

ROTARY BOOSTER PUMP 3:1



**205 LITRE (55 GALLON)
IN UNDER 3 MINUTES**

- Built in Gears - One turn of the handle turns the rotor 3 times
- Die cast Aluminium construction
- Includes 2" bung & 3 pc steel suction tube
- Use with: Diesel, Kerosene, Gasoline

RB-3

With metal
outlet spout

RB-3H

With 8' (1.8 m)
delivery hose &
metal nozzle



DOUBLE DIAPHRAGM TRANSFER PUMP



UPTO 800 ML/STROKE

DPP-1

- Die cast Aluminium pump for use on farms, ranches, construction sites etc.
- Stainless steel piston & fuel resistant hi-nitrile diaphragm
- Complete with telescopic steel suction tube & 8' (1.8 m) x 3/4" anti-static rubber hose with die-cast nozzle
- Use with: Diesel, Kerosene, Gasoline & Light Oils



LEVER ACTION FUEL PUMP



UPTO 300 ML (10 OZ.)/STROKE

LBP-85

- All steel construction
- Includes 2" bung & telescopic suction tube
- Fits 50-205 litre (15-55 gallon) drums
- Use with: E85 Fuel, Bio Diesel, Diesel, Kerosene, light oils



INDUSTRIAL ROTARY DRUM PUMPS



UPTO 38 LPM (10 GPM)

- Heavy duty cast iron construction
- High quality sintered powder metal rotor
- Graphite vanes & seals
- Includes 2" bung & telescopic steel suction tube with strainer

RBP-3V/F

Use with Class I & Class II flammable & combustible liquids such as Gasoline, Naphtha, Alcohols & other solvents



RBP-3V/H/F

Use with Class I & Class II flammable & combustible liquids such as Gasoline, Naphtha, Alcohols & other solvents



RBP-3V

Use with Diesel, Kerosene & Petroleum based fluids



RBP-3V/H

Use with Diesel, Kerosene & Petroleum based fluids



RBP-3V/H/MT

Use with Diesel, Kerosene



FUEL PUMPS - ELECTRIC

DIESEL PUMPS



UPTO 46 LPM (12 GPM)



EDP

- Portable 1/4 HP Electric Fuel Pump
- Ideal for use on construction sites, farms etc.
- Non corroding aluminium die cast body
- Self Priming Vane Pump
- Duty Cycle: 30 Minutes On / 30 Minutes Off
- Available in: 12V & 24V DC (as pump only or Battery Kit)



Pump only
Base Mount Style



Pump with
Battery Kit



Pump Kit:
Drum Mount Style

DIESEL PUMP - HEAVY DUTY



UPTO 46 LPM (12 GPM)

EDP-HD

- Portable Heavy Duty Electric Fuel Pump
- Ideal for use on excavators, on farms, automotive & industrial applications
- Designed for use in extreme heat
- Non corroding Aluminium Die Cast Body
- Self Priming Vane Pump
- Duty Cycle: 45 Minutes On / 45 Minutes Off

- Available in: 12V & 24V DC
- Includes pump, 2m long battery cable, delivery hose, manual fuel nozzle & suction hose with strainer
- Use with: Diesel, Kerosene



HEAVY DUTY FUEL PUMP



UPTO 57 LPM (15 GPM)

FPM

- **Portable Electric Geared Fuel Pump**
- Ideal for use on construction sites, farms, industrial & automotive application.
- Non corroding Aluminium Die Cast Body
- **Duty Cycle:**
30 Minutes On / 30 Minutes Off
- Available in:
12V & 24V DC; 110V & 220V AC
- Use with: Gasoline, Diesel, Kerosene, Bio-Diesel



EXPLOSION
PROOF MOTOR



SCAN TO
WATCH

CONTINUOUS DUTY FUEL PUMP



UPTO 56 LPM (15 GPM)

GDP

- Diesel Pump for use on Stationary Tanks
- Non corroding Aluminium Die Cast Body
- **Self Priming Vane Pump**
- Available in: 115V & 220V AC
- Use with: Diesel, Kerosene



HIGH FLOW FUEL PUMP



UPTO 75 LPM (20 GPM)

FPM-HF

- **Heavy duty 12V DC Electric Geared Fuel Pump**
- Ideal for use on construction sites, farms etc.
- Non corroding Aluminium Die Cast Body
- **Duty Cycle:**
30 Minutes On / 30 Minutes Off
- Use with: Gasoline, Diesel, Kerosene, Bio-Diesel



EXPLOSION
PROOF MOTOR



MINI BOWSER DIESEL REFILLING SYSTEM



UPTO 44 LPM (11 GPM)

CBN

- Compact system for stationary diesel refilling applications
- **Continuous Duty**
- Complete with:
 - 1/2 HP Electric fuel pump
 - Mechanical fuel meter $\pm 1\%$,
 - Auto shut off fuel nozzle with swivel
 - Nozzle holder, 10-1/2' x 1" ID anti static fuel hose & hose hangar
- Available in: 115V & 220V AC
- Use with: Diesel & Kerosene

OIL & FUEL PUMP



UPTO 40 LPM (10.5 GPM)

EOP

- Portable Electric Fuel Pump with 0.43 HP Motor
- Ideal for light industrial, automotive, heating & marine applications
- Non corroding POM Body
- **Continuous Duty**
- Available in: 12V & 24V DC; 110V & 220V AC
- Use with: Diesel Light Oils, Kerosene, Water, Antifreeze, Windshield fluid



SCAN TO
WATCH

DEF PUMPS

ELECTRIC PUMPS



UPTO 34 LPM (9 GPM)

- Diaphragm Transfer pump
- Polypropylene construction
- **Duty Cycle: 30 Mins On / 30 Mins Off**
- Available in: 220V & 110V AC; 12V DC
- Use with: DEF, Urea, Antifreeze, Detergents etc.

DEFP-12

IP55



DEFP-115



ELECTRIC STAINLESS STEEL PUMP



UPTO 56 LPM (15 GPM)

IP54

DEFP-SS

- SS304 Stainless steel durable construction
- **Centrifugal Vane Pumping Mechanism** for enhanced suction lift even when run dry
- Totally enclosed motor for safe operation
- **Continuous Duty**
- Available in: 115 AC & 220V AC
- Use with: DEF, Urea, Antifreeze, Detergents etc.



NEW!

TRANSFER SYSTEMS



UPTO 34 LPM (9 GPM)

- Ready to use kits
- Use with: DEF, Urea, Water, Antifreeze

KIT-IBC

Tote Mounting Kit



Drum & tote not included

KIT-DRM

Drum Mounting Kit



AIR OPERATED TRANSFER PUMPS



UPTO 30 LPM (8 GPM)

PAOP

- Air Operated Transfer Pump
- Includes 2" bung & telescopic suction tube
- Fits 50-205 L (15-55 gallon) drums
- Available as pump only & pump with delivery hose and nozzle
- Use with: DEF, Antifreeze, Water, Oils, Windshield Fluid, Herbicides & Pesticides



Drum not included

PLASTIC LEVER PUMPS



UPTO 500 ML (1 PINT)/STROKE

PLP-02

- Lever action pump for use with thick oils, agricultural chemicals etc.
- Lock nut to mount pump in any position
- Fits 50- 205 litres (15-55 gallon) drums
- Use with: DEF, Antifreeze, Windshield Fluid, Water, Oils Herbicides & Pesticides



LEVER ACTION PISTON PUMP



UPTO 500 ML (1 PINT)/STROKE

PLP-10

- Ergonomic design for fatigue free use
- Use with: DEF, Antifreeze, Windshield Fluid, Water, Oils Herbicides & Pesticides



Lever Handle Convenient Up-Down Movement

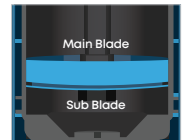

Double Blade Airtight Design



Swivel Bung Adaptor



Superior fracture resistant, non-kink hose



Hose Clamp with Hose Holder

ELECTRIC DRUM/IBC PUMP



UPTO 28 LPM (7.4 GPM)

EDR-55

- Electric Drum Pump for dispensing DEF
- Duty Cycle: 15 minutes ON/15 minutes OFF
- Fits 205 litres (55 gallon) drums or 1000-1250 litres (275-330 gallon) IBC's

AVAILABLE IN 3 CONFIGURATIONS

1. 12V DC
2. 100-240V AC
3. Rechargeable Li-Ion Battery

- Use with: Diesel, Kerosene, DEF, Water & water based fluids



ELECTRIC DRUM PUMP



UPTO 16 LPM (4.2 GPM)

EDR-205

- Dual Power Pump works on AC & DC supply
- Telescopic suction tube suitable for 50-205 litre (15-55 gallon) drums
- Use with: Motor Oil, Hydraulic Oil, Diesel, Kerosene, DEF, Water & water based fluids, Antifreeze, Windshield Water, Agricultural chemicals etc. (Max. 100 cst)
- Duty Cycle 15 minutes ON/15 minutes OFF



Power Input



Nozzle holder

BATTERY TRANSFER PUMP



UPTO 10 LPM (2.6 GPM)

BOP-5A

- Self priming pump with 3V DC motor
- Pump is operated by sliding the actuation button on top
- Ideal for transferring small quantities of media into boats, garages & small shops
- **Battery Capacity:**
One set of batteries delivers upto 1000 litres (264 gallons)
- Use with: Diesel, Kerosene, Water, Light Oil, DEF, Antifreeze, Detergents, Water



2xD Batteries (not included)

DRY CELL DEF PUMP



UPTO 9 LPM (2.3 GPM)

BOP-50

- Self priming pump with 3V DC motor
- Convenient to operate trigger for full control on fluid outflow
- No spillage even when the electric switch is ON
- **Battery Capacity:**
Fully charged battery can dispense 1000 litres (264 gallons)
- Use with: Gasoline, DEF, Diesel, Kerosene, Antifreeze, Windshield Fluid, Detergents



2xD Batteries (not included)



SCAN TO WATCH

RECHARGEABLE PUMP **NEW!**



UPTO 11.5 LPM (3.04 GPM)

BOP-60

- Rechargeable battery operated pump with Control Nozzle for:
 - a. Full control on fluid outflow
 - b. No spillage even when switch is ON
- Power Source: 2900mAh rechargeable Lithium ion battery (USB cable included)
- **Battery Capacity:**
Fully charged battery can dispense upto 300 litres (79 gallons)
- Use with: Gasoline, Diesel, Kerosene, DEF, Water, Antifreeze, Agricultural Chemicals etc.



Li-ion Battery (2900 mAh) (USB cable included)



SCAN TO WATCH

BATTERY FUEL TRANSFER PUMP AUTO SHUT OFF



UPTO 9 LPM (2.4 GPM)

BOP-10

- 12V DC battery operated pump
- In-built auto shut off sensor in the nozzle prevents overflow & wastage of fuel
- **Hands free operation**
- Use with: Diesel, Kerosene, Light Oil, Dirty Water



SUBMERSIBLE DIESEL PUMP



UPTO 15 LPM (4 GPM) AT 1M HEIGHT

SDP

- 12V DC Powered Submersible Pump
- Pump motor covered with water tight and rust-proof PVC casing making it useful as a submersible unit
- **Duty Cycle:**
60 Mins On / 60 Minutes Off
- Use with: Diesel, Kerosene, Water, Light Oils & DEF



NYLON CHEMICAL PUMPS

- Self priming vertical lift pump
- Nylon construction with stainless steel plunger rod & PTFE seals
- Use with: Oil, Bio Diesel, Water, DEF, Antifreeze, Urea, Windshield Fluid, Lacquers & Thinners

CMP-12

FLOW RATE
Upto 400 ml (14 oz) / stroke

For use on 205 litre (55 gallon) drum



CMP-12S

FLOW RATE
Upto 190 ml (6.3 oz) / stroke

For use on 25 litre drums



SPECIALITY PUMPS

316 STAINLESS STEEL VERTICAL LIFT PUMP



UPTO 600 ML (20 OZ) / STROKE

VLP-SS

- Stainless Steel body with PTFE piston
- In-built lock nut for grounding wires
- Flow control tubes to regulate flow
- Includes Bung adaptor for use with Metal & Plastic Drums
- Use with: Thinners, Acetone, Benzene, Naphtha, Fuels, Oils, Urea, DEF, Photographic Chemicals, Solvents



PLASTIC ROTARY PUMPS



UPTO 5 LITRES (1.3 GALLONS) / 20 TURNS

STANDARD

ERP-01

- PPCP rotor with PPCP handle & viton seals
- 2" bung adaptor
- Use with: Light Oils & Antifreeze



PROFESSIONAL

PRP-01

- Ryton rotor with 40% glass filled PP handle & viton seals
- 2" bung adaptor
- Use with: Acids, Chemicals, antifreeze, Water based media, DEF, Urea, Benzene, Glycerine etc.



DEF

PRP-02

- Polypropylene rotor with 40% glass filled PP handle & viton seals
- 2" bung adaptor
- Use with DEF & Urea



HEAVY-DUTY

PRP-10

- Ryton rotor with aluminium die cast handle & PTFE seal
- 2" CI bung adaptor
- Use with: Esters, Alcohols, Acetone, Bases, Hydrocarbon, Water, Antifreeze, Urea, DEF



STAINLESS STEEL ROTARY DRUM PUMP



UPTO 4 LITRES (1 GALLONS) / 20 TURNS

GNB-SS

- 304 Stainless Steel & PTFE construction
- 2" bung adaptor
- Fits 50-205 litre (15-55 gallon) drums
- Use with: Water based media, antifreeze, acids, chemicals, lacquer, thinner, Urea, DEF



POLYPROPYLENE CHEMICAL PUMP



UPTO 400 ML (14 OZ. / STROKE)

CMP-10

- Polypropylene construction with steel plunger rod & viton seals
- Complete with 2" polypropylene bung adaptor for use on 205 litre (55 gallon) drums
- Use with: Detergents, Antifreeze, Windshield Fluid, Glycerine, Mild acids, Most petroleum based media



TIRE SEALANT PUMP



UPTO 230 ML (8 OZ.) / STROKE

TSP-03

- Hand operated Pump for pumping Tire Sealant from 5 to 6-1/2 gallon pails directly into tubeless tyres
- Complete with 5' (1500 mm) braided PVC hose fitted with quick connect coupler and return valve

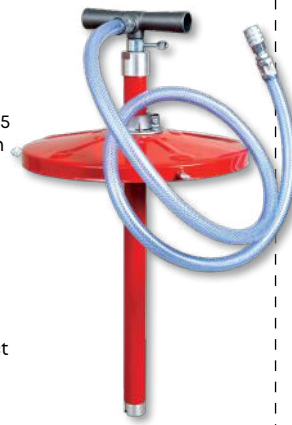

SIPHON PUMPS



UPTO 9 LPM (2.4 GPM)

- Polyethylene pumps siphon liquids to lower levels than the height at which pump is installed
- Easy to prime pumps start within 6-7 strokes and keep working in auto mode
- Vent cap to stop fluid outflow
- Use with: Antifreeze, Water based fluids, Detergents, Soaps & Mild acids

SPH-1

- Flow Rate 6.5 LPM (2 GPM)



For use with 5-20 litre (5 gallon) pails

SPH-2

- Flow Rate 17.5 LPM (5 GPM)



For use with 205 litre (55 gallon) drums

SPH-3

- Flow Rate 21 LPM (7 GPM)



For use with 205 litre (55 gallon) drums

PLASTIC LEVER PUMP VALUE

NEW!

PLP-20

- Polypropylene pump with stainless steel piston rod and viton seal
- Dual bung adaptor for use on drums with 1-1/2" & 2" openings
- Telescopic suction tube for use on 50-205 litre (15-55 gallon drums)



VARIABLE HANDLE SETTING

Flow Setting	Low FLOW 1	Medium FLOW 2	High FLOW 3
Flow Rate*	Upto 270 ml (9 Oz.) /Stroke	Upto 350 ml (12 Oz.) /Stroke	Upto 430 ml (15 Oz.) /Stroke
Type of Fluids	Lubricants or liquids under 35 cst	Anti-freeze, Alcohols, Water, Water based chemicals, low viscosity lubricants	Diesel, Kerosene, Petroleum-based non-corrosive liquids upto 100 cst

* Measured at pump outlet. Tested using water

316 STAINLESS STEEL SAFETY PUMPS



UPTO 4 LITRES (1 GALLONS) / 20 TURNS

VLPSS-FM

- 304 Stainless Steel & PTFE construction
- Built-in flame arrestor
- Bonding and grounding wires prevent static charge
- Fits 50-205 L (15-55 gl.) Drums
- Use with: Gasoline, Diesel, DEF, Naptha, Diesel & Kerosene

Delivers

Upto 200 ml (7 oz) / stroke



BRASS TRANSFER PUMPS

- Portable hand pumps for clean, quick, hassle free transferring or evacuating of a wide variety of media
- Small & lightweight, these fit easily in a tool box or the trunk of a car
- Use with: Engine Oil, Coolants, Transmission Fluid, Power Steering Fluid, Oils, Diesel, Water, Antifreeze

BLG-1

With dipstick hose

Flow Rate
Upto 400ml (14oz)/
stroke



BLG-2

Flow Rate
Upto 190ml
(6.3oz)/stroke



For detailed compatibility chart write to use info@groz-tools.com

DIAPHRAGM / BILGE PUMP



UPTO 16.6 LPM (4.40 GPM)

DPP-20

Pump with

- Suction & discharge hose (1" I.D. x 2 m)
- Delivery nozzle
- Hose clamps
- Drum attachment kit for converting pump for mounting on drums with a 2" opening, complete with suction drum hose (3/4" I.D. x 1.25 m)
- Connecting links & strainer



DPP-20A

Complete with suction & discharge hose (1" I.D. x 2 m long), delivery nozzle & hose clamps

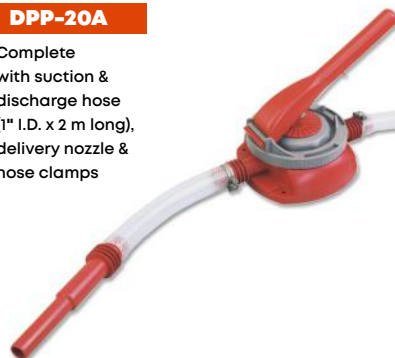

DPP-20B

Pump only with 1" (25 mm) inlet & outlet hose barb ports



- Designed to work in any position-vertical, horizontal, at an angle or even upside down
- Constructed from minimal parts, the pump is virtually maintenance free

METERS, NOZZLES & ACCESSORIES

FUEL METER MECHANICAL

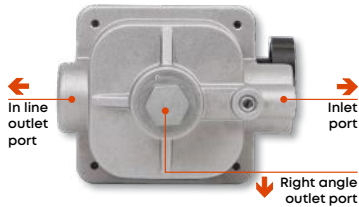

FM100

Accuracy: $\pm 2\%$
Nutating Disc Mechanism

- Robust aluminium construction
- **Flow Rate: 15-75 LPM (4-20 GPM)**
- Use with: Diesel, Gasoline, Low to Medium Viscosity Oils
- Register cap can be easily removed & rotated to every 90° orientation for display reading

VERSATILE MOUNTING OPTIONS

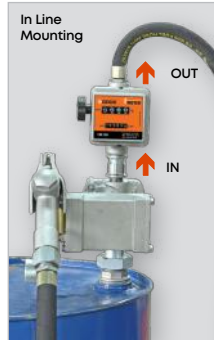

DIGITAL FUEL METER OVAL GEAR

FM25

Accuracy: $\pm 0.5\%$
Oval Gear Mechanism



- Digital meter for highly accurate readings
- Comes factory calibrated for use with diesel with reduced loss of head
- Measures in litres, quarts, pints & gallons
- **Flow Rate: 10-100 LPM (2.64-26.4 GPM)**
- Use with: Diesel, Oils, Antifreeze

DIESEL METER MECHANICAL

FM10

Accuracy: $\pm 1\%$
Nutating Disc Mechanism



SCAN TO WATCH



- Aluminium construction
- Designed for inline application and gravity flow
- Register cap can be removed and rotated to 90° angles
- **Flow Rate: 20-120 LPM (5-32 GPM)**
- Use with: Diesel, Bio-diesel & light oils

DIGITAL FUEL METER HEAVY DUTY

FM20

Accuracy: $\pm 1\%$
Turbine Mechanism



- Digital meter for in-line or end of line applications
- Measures in litres, quarts, pints & gallons
- **Flow Rate: 5-120 LPM (1.3-30 GPM)**
- Use with: Diesel, Gasoline, Bio-diesel

DIGITAL FUEL METER PROFESSIONAL

IP55

FM2000

Accuracy: $\pm 1\%$
Turbine Mechanism



- Digital turbine meter for in-line or end of line applications
- Bi-directional - Either ports can be used as inlet/outlet
- Measures in litres, quarts, pints & gallons
- **Flow Rate: 4-120 LPM (1-30 GPM)**
- Use with: Diesel, Gasoline, Bio-diesel

DEF METERS

DIGITAL DEF METER HEAVY DUTY

WM20

Accuracy: $\pm 1\%$
Turbine Mechanism



- Digital turbine meter designed for in-line, end of the line applications or use with a dispensing nozzle
- Measures in litres, quarts, pints & gallons
- **Flow Rate: 5-120 LPM (1.3-30 GPM)**
- Use with: Urea, DEF, Windshield Fluids, Water & Water based media

DIGITAL DEF METER PROFESSIONAL

WM2000

Accuracy: $\pm 1\%$
Turbine Mechanism



- Digital turbine meter designed for in-line, end of the line applications or use with a dispensing nozzle
- Polypropylene body & sealed electronic card make it weather-proof
- Measures in litres, quarts, pints & gallons
- **Flow Rate: 4-120 LPM (1-30 GPM)**
- Use with: Urea, DEF, Windshield Fluids, Water & Water based media

FUEL CONTROL NOZZLES - MANUAL



50 PSI (3.45 BAR)

FCN

- Aluminium construction
- Manual Flow Control:** Comes with a continuous flow switch for unattended dispensing
- Flow Rate: Upto 75 LPM (20 GPM)**
- Available in two inlet sizes (with & without Swivel):
 - 3/4" for use with Diesel & Gasoline
 - 1" for use with Diesel



FUEL CONTROL NOZZLES - AUTOMATIC



50 PSI (3.45 BAR)

FCNA

- Heavy duty Aluminium body with thermoplastic trigger & guard
- Dual Mode - Manual & Automatic:** Sensor in the discharge spout automatically shuts off supply once fuel level in the tank reaches level of outlet spout
- Flow Rate: Upto 110 LPM (29 GPM)**
- Available in two inlet sizes (with & without Swivel):
 - 3/4" for use with Diesel & Gasoline
Flow Rate: Upto 60 LPM (15.87 GPM)
 - 1" for use with Diesel
Flow Rate: Upto 100 LPM (26.45 GPM)

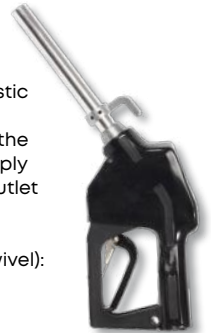

AUTO SHUT-OFF SAFETY FUEL NOZZLE



50 PSI (3.45 BAR)

FCNA-CG

- Heavy duty cast aluminium body with thermoplastic trigger & guard
- Nozzle automatically shuts off:
 - When fuel tank is full
 - When pump is switched off accidentally
 - Accidental fall of nozzle
 - Nozzle is lifted from the tank
- Available in two inlet sizes:
 - 3/4" for use with Diesel & Gasoline
Flow Rate: Upto 60 LPM (15.87 GPM)
 - 1" for use with Diesel
Flow Rate: Upto 100 LPM (26.45 GPM)



DEF CONTROL NOZZLE MANUAL



50 PSI (3.45 BAR)

FCN-NY

- Nylon construction with stainless steel internal parts & viton seals
- Manual Control.** Also includes continuous flow switch for unattended dispensing
- 3/4" hose barb at inlet
- Flow Rate: Upto 20-90 LPM (5-23.8 GPM)**
- Use with: Urea, DEF Water



DEF CONTROL NOZZLE AUTOMATIC



50 PSI (3.45 BAR)

FCNA-SS

- Heavy duty stainless steel body with polyamide cover
- In-built sensor in outlet spout automatically shuts off supply once fluid level in tank reaches that of the outlet spout
- Complete with Stainless Steel swivel with 3/4" hose barb
- Flow Rate: 45 LPM (11.9 GPM)**
- Use with: Urea, DEF, Water & E85 Fuels



DUAL PLANE FUEL NOZZLE SWIVELS



50 PSI (3.45 BAR)

SWV-2P

- Aluminium die cast construction
- Laminar flow design for higher fuel flow
- 360° rotation for free movement facilitating flexibility to refuel vehicles from any direction
- Available in 2 thread size: 3/4" & 1"
- Use with: Diesel, Kerosene, Gasoline, Bio-Diesel



STAINLESS STEEL NOZZLE SWIVEL



50 PSI (3.45 BAR)

SWV-SS

- Stainless Steel SS 304 construction
- 3/4" (20 mm) hose barb at one end and 3/4" male threads on the other
- 0.55" (14 mm) ID designed for minimal back pressure
- Use with: Urea, DEF, Water & Windshield Fluids



FUEL HOSE ANTI-STATIC

ZSA-HOS

- Anti static fuel hose complete with end connections
- Use with: Diesel, Kerosene, Gasoline



FUEL HOSE - NON GROUNDED

HOS-EDP

- Use with: Diesel, Kerosene, Gasoline



FUEL DISPENSING KIT

FDK

- Gravity feed fuel dispensing kit comprising 3 m (10') hose fitted with manual fuel control nozzle with swivel



FUEL FILTERS



50 PSI (3.45 BAR)

- Durable lightweight design for installation on mobile and stationary fuel tanks and on diesel & gasoline fuel pumps
- Standard filters come with 10 micron filter element
- Spare filters for removing particulate & water available

FFL-01

- ISO plast see through bowl
- NBR Seal
- Available in 3/4" & 1" inlet sizes
- For Gasoline, Gasohol, Diesel, Kerosene & Bio-Diesel (blends upto 20%)



FFL-01BD

- ISO plast see through bowl Viton Seals
- Available in 1" inlet size
- For use with 100% Bio-diesel, Gasoline, Diesel, Fuel oils, methyl, ethyl & isopropyl alcohols



FFL-02

- Translucent polypropylene bowl
- NBR Seals
- Available in 1" inlet size
- For Diesel, Kerosene & Gasoline



FUEL FILTERS - SPIN ON CARTRIDGE STYLE



50 PSI (3.45 BAR)

FFS-10

- **Flow Rate: Upto 94 LPM (25 GPM)**
- High flow fuel filter with 10 micron spin-on type filter cartridge
- Aluminum die cast head fits on 1-1/2" -16 UNF threaded cartridges
- For use both on mobile & stationary fuel tanks in agricultural and construction sites
- Available in 3/4" & 1" inlets
- Use with: Gasoline, Diesel, Ethanol & Methanol blend upto 10%



PORTABLE FUEL FILTER



UPTO 13 LPM (3.45 GPM)

FUF-13

- Designed to filter out water, contaminants and debris upto 100 micron from fuels & light oils
- Patented vertical filter design free flow of fluids without pressure on the filter screen like in horizontal filters
- Teflon coated maintenance free filter screen
- Rugged polypropylene body with carbon additive makes the funnel conductive which grounds static electricity that may be produced when handling fluids
- Use with: Diesel, Kerosene, Gasoline & Light Oils



SCAN TO WATCH

FILTER WRENCH

FW-FFL

- Weather resistant, re-inforced, Nylon wrench used for removing filter bowl without damage when changing filter element
- Fits GROZ FFL-01, FFL-01 and several other filters



BREAKAWAY VALVE

BKV

- Inline breakaway valve designed to be installed between the fuel dispenser & nozzle
- Tolerant of pulsing and line shocks due to sturdy yet lightweight aluminium design body
- PVC sleeve provides better grip and handling
- Designed to pull apart at Max. 1500N/350 lbs. pull force
- Small & light weight with minimal flow restriction
- Use with: Aluminium, Nylon & Viton



1" Breakaway Valve

3/4" Breakaway Valve

06 drum handling

DRUM DOLLIES

DRUM DOLLIES

- Heavy duty 3 mm (11 gauge) steel sheet construction suitable for convenient transportation of 205 litres (55 gallon) drums on shop floors & rough workshop environments
- Hold drums of diameter 23" (584 mm)

BDL-140

- Phenolic Castors
3"x1-1/4" (75x32 mm)
- Load Bearing Capacity:
400 kg (900 lbs)



BDL-141

- Polyolefin Castors
3"x1-1/4" (75x32 mm)
- Load Bearing Capacity:
450 kg (1000 lbs)
- Available in two sizes

For use with 110 litres (30 gal.) drum



BDL-151

- Polyolefin Castors
3"x1-1/4" (75x32 mm)
- 5 cross braces for higher
support & load capacity
- Load Bearing Capacity:
567 kg (1250 lbs)



BDL-180

- Nylon Castors
4"x1-1/4" (101x32 mm)
- 8 castors for highest balance
- Load Bearing Capacity:
910 kg (2000 lbs)



BDL-140S

- Cast Iron Castors
3"x1-3/8" (75x35 mm)
- Load Bearing Capacity:
545 kg (1200 lbs)



For use with 205 litres (55 gal.) drum



BDL-151S

- Cast Iron Castors
3"x1-1/4" (75x32 mm)
- Load Bearing Capacity:
635 kg (1400 lbs)



DRUM CRADLES

- Tips, rotates, moves & stores 400 lbs. / 180kg / 205 litre / 55 gal. drums
- Large 2-1/2" (63 mm) non-sparking wheels for use in flammable environments
- Maximum load 600 lbs. / 273 kgs

DRC-133

- Type: Movable
- 2 Rigid & 2 Swivel Wheels
- Axle: Yes



DRC-135

- Type: Movable
- 4 Rigid Wheels
- Axle: Yes



DRC-137

- Type: Stationary
- Without wheels
- Axle: No



SCAN TO
WATCH

BAND DOLLIES

- Welded 3 mm (11 gauge) steel sheet construction with premium powder coated finish
- Can be adjusted easily for varying barrel/pail diameters

BDL-60

- Castors: 4 Phenolic Castors
- Drum Dia.: 15" to 15-3/4" (381 to 400 mm)
- Suitable for Pails of: 60 kg pails
- Load Bearing Capacity: 90 kg (200 lbs)



BDL-120

- Castors: 4 Phenolic Castors
- Drum Dia.: 13-1/2" to 14-1/4" (343 to 362 mm)
- Suitable for Pails of: 120 lbs./50 kg/16 gal. pails
- Load Bearing Capacity: 90 kg (200 lbs)



BDL-130

- Castors: 5 Phenolic Castors
- Drum Dia.: 18" to 19" (457 to 482 mm)
- Suitable for Pails of: 130 gal. containers
- Load Bearing Capacity: 114 kg (250 lbs)



BDL-105

- Castors: 4 Phenolic Castors
- Drum Dia.: 10-1/4" to 11-9/32" (260 to 287 mm)
- Suitable for Pails of: 25-50 lbs./20 kg/5 gal. pails
- Load Bearing Capacity: 90 kg (200 lbs)



BDL-120S

- Castors: 4 Cast Iron Castors
- Drum Dia.: 13-1/2" to 14-1/4" (343 to 362 mm)
- Suitable for Pails of: 120 lbs./50 kg/16 gal. pails
- Load Bearing Capacity: 136 kg (300 lbs)



BDL-130S

- Castors: 5 Cast Iron Castors
- Drum Dia.: 18" to 19" (457 to 482 mm)
- Suitable for Pails of: 130 gal. containers
- Load Bearing Capacity: 170 kg (374 lbs)



DRUM TROLLEYS

- Manufactured from heavy gauge 4 mm thick steel sheet
- 3" (75 mm) ground clearance for smooth movement over uneven surfaces in workshop environment
- 6" (150 mm) wide polyurethane front wheels with nylon rim for reduced wear & tear
- Available in 2 sizes:

TRL-180H

Trolley for 180 kg / 55 gal. / 205 litre drums

Load Capacity: 300 kg (660 lbs.)

Use as a trolley or as a dispensing system with pump & hose reel.



Removable handle used for moving the trolley



Removable handle used as a drum loader

Removable handle used as a drum wrench



TRL-50

Trolley for 50 kg / 120 lb. drums

Load Capacity: 80 kg (170 lbs.)



DRUM CARTS

- Tough Built carts for moving drums on shop floor
- Fitted with lathe 10" dia. front wheels & 5" dia. nylon rear wheels
- Wheels available in a choice of Pneumatic or Phenolic

CART-120



For 50 kg / 60 litre / 120 lb pails

CART-400



For 180 kg / 205 litre / 400 lb / 55 gal. drums

NEW!

DRUM TROLLEY **NEW!**

TRL-30

- Tough built trolley for convenient movement of 20-30kg drums in workshops and industrial environments
- Ideal for transporting oil / grease barrels, as well as installing air operated pump



DRUM TROLLEY LOW PROFILE

TRL-55

- Made from 5 mm (6 gauge) sheet, with a loading capacity of 545 kgs (1200 lbs)
- For drums up to a dia. of 26" (660 mm)



DRUM TROLLEY ADJUSTABLE

TRL-60

- Adjustable drum trolley for use with 25-50 lbs. / 5 gal. / 20 litre drums to larger drums upto 120 lbs / 16 gal. / 60 litre capacity
- Heavy duty wheels for use in rigorous workshop environment



DRUM BUNG CONVERTERS

BUNG/P/TS

2" (F) TRI-SURE ADAPTOR

2" Fine Male threads found on most pumps / drum bungs to 2" Male threads for use on drums with female Tri Sure threads



BUNG/P/MS

2" (F) MAUSER ADAPTOR

2" Fine Male threads found on Most pumps / drum bungs to 2" Male threads for use on drums with female Mauser threads (popular on many IBC's / Totes)



BUNG/P/2B

2" (F) COARSE THREAD ADAPTOR

2" Fine Male threads found on Most pumps / drum bungs to 2" Male coarse threads for use on plastic drums with coarse female threads



DRUM WRENCH

DRW

- Cast aluminum (LM25), construction
- Designed to fit perfectly onto most 2" & 3/4" drum plugs



For opening hex plugs



For opening 2" drum plugs



For opening 3/4" drum plugs

DRUM LEVEL INDICATOR

DLI

- An easy & cost effective means to check level of fluid in a drum / tank
- Fits on the small 3/4" hole leaving the 2" opening on drums free for installing pump
- Planetary gear mechanism float connected with a string moves down as the liquid level goes down in the drum.
- For use on drums (55 gal/205 litre)
- Use with oil, fuel, water, coolants etc.



SCAN TO WATCH

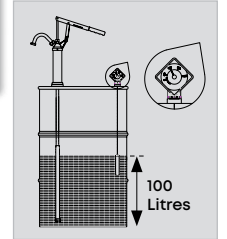
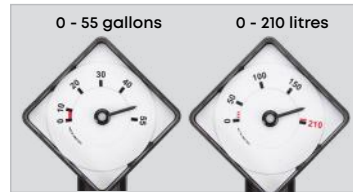

DRUM FAUCETS / TAPS WITH BUCKET HANGER

FAU/0-2

- For 2" openings

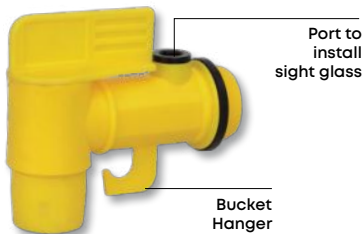

FAU/3-4

- For 3/4" openings

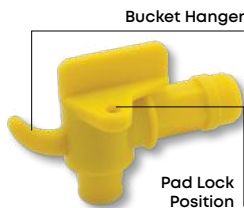

SCAN TO WATCH

DRUM FAUCETS/TAPS

NEW!

- Can be used on plastic & metal drums
- Use with non-corrosive media, light oils, water, mild-chemical etc.

FAU/50

- For 2" openings



FAU/25

- For 3/4" openings



DRUM FAUCET/TAP - FOOD GRADE

NEW!

FAU/25/CL

- For 3/4" openings
- For use with non-flammable liquids and chemicals



07 air handling

FILTER, REGULATOR & LUBRICATOR

AIR REGULATORS



220 PSI (15 BAR)

- Regulators step down the air line pressure and can be set at any desired pressure below the inlet air pressure
- Pressure adjustment range: 7-145 PSI (0.5-10 BAR)
- Factory Tested: 100%
- Mounting: Modular & Panel

R13

Type: Miniature
Port Size: 1/8", 1/4"
Max Flow Rate: 600 LPM (21CFM)

R14

Type: Intermediate
Port Size: 1/4", 3/8"
Max Flow Rate: 2500 LPM (88 CFM)

R15

Type: Standard
Port Size: 1/2"
Max Flow Rate: 4000 LPM (140 CFM)

R17

Type: Heavy Duty
Port Size: 3/4" & 1"
Max Flow Rate: 6000 LPM (210 CFM)

ISO 6953-1



PRECISION REGULATORS



220 PSI (15 BAR)

- Designed to provide precise and constant pressure output from a fluctuating supply pressure
- Sensitive to within 0.2% of full span with repeatability of within +/-0.50% of full span
- Pressure adjustment range: 1.45-116 PSI (0.1-8 BAR)
- Factory Tested: 100%
- Mounting: Modular & Panel

PR13

Type: Miniature
Port Size: 1/4"
Max Flow Rate: 1200 LPM (42CFM)

PR15

Type: Standard
Port Size: 1/2"
Max Flow Rate: 7500 LPM (265 CFM)

ISO 6953-1



AIR FILTERS



145 PSI (10 BAR)

- Filters are used to separate dust, dirt, moisture & other contaminants from compressed air
- Die-cast aluminium head, polycarbonate bowl with steel bowl guard
- Includes 40 microns sintered bronze filter element
- Press type semi-automatic drain that automatically drains out the bowl once compressed air supply is switched off
- Factory Tested: 100%

F13

Type: Miniature
Port Size: 1/8" & 1/4"
Max. Flow Rate: 28 CFM / 800 LPM
Threaded type steel bowl guard

F14

Type: Intermediate
Port Size: 1/4" & 3/8"
Max. Flow Rate: 80 CFM / 2250 LPM
Bayonet type steel bowl guard

F15

Type: Standard
Port Size: 1/2"
Max. Flow Rate: 125 CFM / 3500 LPM
Bayonet type steel bowl guard

F17

Type: Heavy Duty
Port Size: 3/4" & 1"
Max. Flow Rate: 230 CFM / 6500 LPM
Bayonet type steel bowl guard

ISO 5782-1



AIR FILTERS - METAL BOWL



290 PSI (20 BAR)

- Filters are used to separate dust, dirt, moisture & other contaminants from compressed air
- Aluminium die-cast filter head & bowl
- Includes 40 microns sintered bronze filter element
- Press type semi-automatic drain that automatically drains out the bowl once compressed air supply is switched off
- Suitable for use in chemical plants, foundries etc where ambient air may contain chemicals such as acetone, benzene, kerosene, ethylene dichloride etc.
- Factory Tested: 100%

F13-M

Type: Miniature
Port Size: 1/8" & 1/4"
Max. Flow Rate: 28 CFM / 800 LPM

F14-M

Type: Intermediate
Port Size: 1/4" & 3/8"
Max. Flow Rate: 80 CFM / 2250 LPM

F15-M

Type: Standard
Port Size: 1/2"
Max. Flow Rate: 125 CFM / 3500 LPM

F17-M

Type: Heavy Duty
Port Size: 3/4" & 1"
Max. Flow Rate: 230 CFM / 6500 LPM

ISO 5782-1



COALESCING FILTERS



145 PSI (10 BAR)

- Also referred to as Mist Separators, these are used to remove submicronic oil, water droplets and solid contaminants from compressed air
- Used for efficient filtration of compressed air (99.99%) removing fine oil particles upto 0.01 microns
- Die cast aluminium head, polycarbonate bowl with steel bowl guard
- Borosilicate filter element: 0.10 microns & 0.01 microns
- Used primarily in Chemical plants, Medical, Food Processing, Paint Shops, Air gauging & other precision pneumatic systems

FS13

Filter: 0.10 Microns
Type: Miniature
Port Size: 1/8" & 1/4"
Max. Flow Rate: 25 CFM / 700 LPM

FS14

Filter: 0.10 Microns
Type: Intermediate
Port Size: 1/4" & 3/8"
Max. Flow Rate: 57 CFM / 1600 LPM

FS15

Filter: 0.10 Microns
Type: Standard
Port Size: 1/2"
Max. Flow Rate: 124 CFM / 3500 LPM

FS13

Filter: 0.01 Microns
Type: Miniature
Port Size: 1/8" & 1/4"
Max. Flow Rate: 11 CFM / 300 LPM

FS14

Filter: 0.01 Microns
Type: Intermediate
Port Size: 1/4" & 3/8"
Max. Flow Rate: 32 CFM / 900 LPM

FS15

Filter: 0.01 Microns
Type: Standard
Port Size: 1/2"
Max. Flow Rate: 48 CFM / 1350 LPM

FS17

Filter: 0.01 Microns
Type: Heavy Duty
Port Size: 3/4" & 1"
Max. Flow Rate: 78 CFM / 2200 LPM

ISO 8573-1



AIR LUBRICATORS



145 PSI (10 BAR)

- Air Lubricators are used to feed lubricants to pneumatic equipment. These maintain a constant oil-to-air density over a wide range of flow
- Fog/Micro mist type, upto 50' pipe runs
- Die cast aluminium head, polycarbonate bowl with steel bowl guard
- Head fitted with oil drop indicator, controller & oil filling plug
- Factory Tested: 100%

L13

Type: Miniature
Port Size: 1/8" & 1/4"
Max. Flow Rate: 48 CFM / 1350 LPM

L14

Type: Intermediate
Port Size: 1/4" & 3/8"
Max. Flow Rate: 106 CFM / 3000 LPM

L15

Type: Standard
Port Size: 1/2"
Max. Flow Rate: 200 CFM / 5650 LPM

L17

Type: Heavy Duty
Port Size: 3/4" & 1"
Max. Flow Rate: 318 CFM / 9000 LPM

ISO 6301-1



AIR LUBRICATORS METAL BOWL

ISO 5782-1



290 PSI (20 BAR)

- Air Lubricators are used to feed lubricants to pneumatic equipment. These maintain a constant oil-to-air density over a wide range of flow
- Fog/Micro mist type, upto 50' pipe runs
- Die-cast aluminium head & bowl
- Metal Bowl makes them good for use in chemical plants, paint shops, pharmaceutical plants, foundries etc. where ambient air may contain chemicals, such as acetone, benzene, kerosene, gasoline, toluene, etc.

L13-M

Type: Miniature
Port Size: 1/8" & 1/4"
Max. Flow Rate: 48 CFM / 1350 LPM

L14-M

Type: Intermediate
Port Size: 1/4" & 3/8"
Max. Flow Rate: 106 CFM / 3000 LPM

L15-M

Type: Standard
Port Size: 1/2"
Max. Flow Rate: 200 CFM / 5650 LPM

L17-M

Type: Heavy Duty
Port Size: 3/4" & 1"
Max. Flow Rate: 318 CFM / 9000 LPM



FILTER REGULATOR COMBINATION



145 PSI (10 BAR)

- The Filter-Regulator Combination is one of the most popular air preparation units. The 2 are assembled together to form a single unit
- Filter: Die cast aluminium head, polycarbonate bowl with steel bowl guard & 40 microns sintered bronze element. Semi automatic drain
- Regulator: Non raising "press to lock" adjusting knob for locking at any set pressure. Pressure adjustment range upto 7-145 PSI (0.5-10 BAR)

FRC13

Type: Miniature
Port Size: 1/8" & 1/4"
Max. Flow Rate: 20 CFM / 550 LPM

FRC14

Type: Intermediate
Port Size: 1/4" & 3/8"
Max. Flow Rate: 77 CFM / 2200 LPM

FRC15

Type: Standard
Port Size: 1/2"
Max. Flow Rate: 106 CFM / 3000 LPM

FRC17

Type: Heavy Duty
Port Size: 3/4" & 1"
Max. Flow Rate: 193 CFM / 5500 LPM



FILTER REGULATOR COMBINATION - METAL BOWL



220 PSI (15 BAR)

- The Filter-Regulator Combination is one of the most popular air preparation units. The 2 are assembled together to form a single unit
- Filter: Die cast aluminium body and bowl & fitted with 40 microns sintered bronze element. Semi automatic drain
- Regulator: Non raising "press to lock" adjusting knob for locking at any set pressure. Pressure adjustment range upto 7-145 PSI (0.5-10 BAR)
- Metal Bowl makes them good for use in chemical plants, paint shops, pharmaceutical plants, foundries etc. where ambient air may contain chemicals, such as acetone, benzene, kerosene, gasoline, toluene, etc.

FRC13-M

Type: Miniature
Port Size: 1/4"
Max. Flow Rate: 20 CFM / 550 LPM

FRC14-M

Type: Intermediate
Port Size: 1/4" & 3/8"
Max. Flow Rate: 77 CFM / 2200 LPM

FRC15-M

Type: Standard
Port Size: 1/2"
Max. Flow Rate: 106 CFM / 3000 LPM

FRC17-M

Type: Heavy Duty
Port Size: 3/4" & 1"
Max. Flow Rate: 193 CFM / 5500 LPM



FILTER-REGULATOR & LUBRICATOR - 2 PC



145 PSI (10BAR)

- Space saving 2 piece Filter-Regulator combination and Lubricator
- Filter: Die cast aluminium body and bowl & fitted with 40 microns sintered bronze element. Semi automatic drain
- Regulator: Non raising "press to lock" adjusting knob for locking at any set pressure. Pressure adjustment range upto 7-145 PSI (0.5-10 BAR)
- Lubricator: Used to feed lubricants to pneumatic equipment. These maintain a constant oil-to-air density over a wide range of flow. Fog/Micro mist type, upto 50' pipe runs
- Available in two types:
 - a. Modular: complete with piping adaptors and wall mounting bracket. Easily remove and replace individual components without disturbing the pipeline
 - b. Compact: complete with wall mounting bracket but no piping adaptors



MODULAR SERIES



COMPACT SERIES

FRCLM-13

Type: Miniature
Port Size: 1/4"
Max. Flow Rate: 18 CFM / 500 LPM

FRCLM-14

Type: Intermediate
Port Size: 1/4" & 3/8"
Max. Flow Rate: 63 CFM / 1800 LPM

FRCLM-15

Type: Standard
Port Size: 1/2"
Max. Flow Rate: 99 CFM / 2800 LPM

FRCLM-17

Type: Heavy Duty
Port Size: 3/4" & 1"
Max. Flow Rate: 140 CFM / 4000 LPM

FILTER-REGULATOR & LUBRICATOR - 2 PC, METAL BOWL



220 PSI (15BAR)

- Filter: Die cast aluminium body and bowl & fitted with 40 microns sintered bronze element. Semi automatic drain
- Regulator: Non raising "press to lock" adjusting knob for locking at any set pressure. Pressure adjustment range upto 7-145 PSI (0.5-10 BAR)
- Lubricator: Used to feed lubricants to pneumatic equipment. Fog/Micro mist type, upto 50' pipe runs
- Metal Bowl makes them good for use in chemical plants, paint shops, pharmaceutical plants, foundries etc. where ambient air may contain chemicals, such as acetone, benzene, kerosene, gasoline, toluene, etc.
- Available in two types:
 - a. Modular: complete with piping adaptors and wall mounting bracket.
 - b. Compact: complete with wall mounting bracket but no piping adaptors



MODULAR SERIES



COMPACT SERIES

FRCLM-13M

Type: Miniature
Port Size: 1/4"
Max. Flow Rate: 18 CFM / 500 LPM

FRCLM-14M

Type: Intermediate
Port Size: 1/4" & 3/8"
Max. Flow Rate: 63 CFM / 1800 LPM

FRCLM-15M

Type: Standard
Port Size: 1/2"
Max. Flow Rate: 99 CFM / 2800 LPM

FRCLM-17M

Type: Heavy Duty
Port Size: 3/4" & 1"
Max. Flow Rate: 140 CFM / 4000 LPM

FILTER-REGULATOR LUBRICATOR - 3 PC



220 PSI (15BAR)

- Filter: Die cast aluminium body and bowl & fitted with 40 microns sintered bronze element. Semi automatic drain
- Regulator: With pressure adjustment range upto 7-145 PSI (0.5-10 BAR)
- Lubricator: Used to feed lubricants to pneumatic equipment. These maintain a constant oil-to-air density over a wide range of flow. Fog/Micro mist type, upto 50' pipe runs
- 100% factory tested
- Available in two types:
 - a. Modular: complete with piping adaptors and wall mounting bracket. Easily remove and replace individual components without disturbing the pipeline
 - b. Compact: complete with wall mounting bracket but no piping adaptors



MODULAR SERIES



COMPACT SERIES

FRLM-13

Type: Miniature
Port Size: 1/4"
Max. Flow Rate: 18 CFM / 500 LPM

FRLM-14

Type: Intermediate
Port Size: 1/4" & 3/8"
Max. Flow Rate: 71 CFM / 2000 LPM

FRLM-15

Type: Standard
Port Size: 1/2"
Max. Flow Rate: 106 CFM / 3000 LPM

FRLM-17

Type: Heavy Duty
Port Size: 3/4" & 1"
Max. Flow Rate: 175 CFM / 5000 LPM

FILTER-REGULATOR LUBRICATOR - 3 PC, METAL BOWL



220 PSI (15BAR)

- 3 piece Filter-Regulator combination and Lubricator
- Filter: Die cast aluminium body and bowl & fitted with 40 microns sintered bronze element. Semi automatic drain
- Regulator: With pressure adjustment range upto 7-145 PSI (0.5-10 BAR)
- Lubricator: Used to feed lubricants to pneumatic equipment. These maintain a constant oil-to-air density over a wide range of flow. Fog/Micro mist type, upto 50' pipe runs
- 100% factory tested
- Available in two types:
 - a. Modular: complete with piping adaptors and wall mounting bracket. Easily remove and replace individual components without disturbing the pipeline
 - b. Compact: complete with wall mounting bracket but no piping adaptors



MODULAR SERIES



COMPACT SERIES

FRLM-13M

Type: Miniature
Port Size: 1/4"
Max. Flow Rate: 18 CFM / 500 LPM

FRLM-14M

Type: Intermediate
Port Size: 1/4" & 3/8"
Max. Flow Rate: 71 CFM / 2000 LPM

FRLM-15M

Type: Standard
Port Size: 1/2"
Max. Flow Rate: 106 CFM / 3000 LPM

FRLM-17M

Type: Heavy Duty
Port Size: 3/4" & 1"
Max. Flow Rate: 175 CFM / 5000 LPM

FRL ACCESSORIES

SPACER

Spacer Blocks are used to connect 2 components in modular assemblies



SPACER WITH PORT FOR AIR OUTLET

It is installed before the lubricator. This allows taking out non lubricated air where required



PIPING ADAPTERS

A piping adapter has a threaded end on one side & sealing rings on the other. The adapters are fitted on both the IN port & the OUT port & the Air line would be screwed into them



WALL MOUNTING BRACKET

- Wall Mounting Bracket is a special type of Spacer Block which is 'T' shaped & has holes to mount on the wall
- These connect 2 components in modular assemblies and make them wall mountable



WALL MOUNTING BRACKET WITH PORT FOR AIR OUTLET

- Installed before the lubricator. This allows taking out non lubricated air where required



SAFETY LOCKOUT VALVES

- Lockout valves are used during maintenance & service of air operated equipment
- Available in two types
 1. Safety Lockout Valve
 2. Safety Lockout Valve with Spacer Kit

LKV13

Type: Miniature
Port Size: 1/4"
Max Flow Rate:
1000 LPM/35CFM

LKV14

Type: Intermediate
Port Size: 3/8"
Flow Rate:
2200 LPM/78CFM

LKV15

Type: Standard
Port Size: 1/2"
Flow Rate:
3250 LPM/115CFM

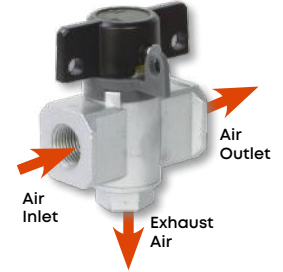

MOUNTING CLAMP FOR INDIVIDUAL FILTERS & LUBRICATORS

- These are steel clamps in powder coated finish, used to mount individual Filters & Lubricators.



MOUNTING CLAMP FOR REGULATORS & FILTER REGULATOR COMBINATIONS

- These clamps are made out of steel in powder coated finish.



REPLACEMENT SINTERED BRONZE FILTER ELEMENTS

- Available in a choice of 5, 25, 40, 50 & 100 microns



REPLACEMENT BOROSILICATE FILTER ELEMENTS FOR COALESCING FILTERS

- Available in a choice of 0.01 & 0.10 microns



REPLACEMENT BOWL FOR FILTERS / LUBRICATORS



PRESSURE GAUGES

- For use with Regulators for setting Output Pressure.
- Available in Digital & Analog version in a choice of 1/8" & 1/4" threads



AUTO DRAIN VALVE EXTERNAL

- The Auto Drain Valve drains the condensate water automatically.
- In addition to automatic draining, there is also provision in the valve for manual draining



AUTOMATIC LINE DRAIN

- Automatic Line Drain is fitted to the main airline piping to drain the condensate as and when collected

NL161

Threads: 1/4" BSP
Condensate Discharge Capacity;
60 ml / minute

NL191

Threads: 1/4" NPT
Condensate Discharge Capacity;
2 oz. / minute



AIR HOSE REEL



217 PSI (15 BAR)

HRP-AW

- Compact Design: For use in confined spaces
- Auto Roll Up: Equipped with slow rewinding mechanism ensuring no one gets hurt
- Hose can be locked at any desired position
- 180° Swivel Wall Bracket
- Hose Length: 15m (50') x 3/8" (10 mm)
- Inlet/outlet threads 1/4" BSPT

NEW!



We also make metal reels. Check out details on page 30

AIR BLOW GUNS & ACCESSORIES

AIR BLOW GUNS PROFESSIONAL



50-235 PSI (3.5 -16 BAR)

ABG

	ABG/1 Plastic Tip	ABG/2 Snub nose rubber tip	ABG/3 4-1/2" (114 mm) long SS nozzle	ABG/4 5-1/2" (140 mm) long SS nozzle fitted with silencer and snub nose rubber tip
STANDARD REACH				
EXTENDED REACH	ABG/3A 13" (330 mm) long SS nozzle	ABG/3B 20" (508 mm) long SS nozzle	ABG/3C 39" (990 mm) long SS nozzle	



AIR BLOW GUN STANDARD

NEW!



50-150 PSI (3.5 -10 BAR)

ABG-10

- Lightweight Air Blow Gun
- Impact and weather resistant nylon body with polyacetal trigger

Also available as a kit with 4 attachments

1/2" (12.7 mm) rubber tip 1" (25 mm) rubber tip 1-3/8" (35 mm) rubber tip Soft rubber star tip nozzle



ABG/10 4-1/2" (114 mm) Nozzle	ABG/10A 13" (330 mm) Nozzle	ABG/10B 20" (508 mm) Nozzle	ABG/10/RT1 4-1/2" (114 mm) Nozzle With Rubber Tip 1/2" (12.7 mm)	ABG/10/SIL 4-1/2" (114 mm) Nozzle With Silencer & Star Rubber Tip



Threaded brass inlet



6 PC INTERCHANGEABLE AIR BLOW GUN KIT

ABG-QR

- Impact & weather resistant nylon body
- Brass threaded air inlet is shear resistant

5

INTERCHANGEABLE ATTACHMENTS



- Rubber Tip (NBR) for steel extensions
- Turbo wide angle nozzle for high volume
- Angled Steel Extension 4" (100 mm)
- Angled Steel Extension 5-1/2" (140 mm)
- Angled Steel Extension 12-1/2" (320 mm)



Quick Release with a simple twist



Brass Inlet



SCAN TO WATCH

METAL BODY SAFETY AIR BLOW GUN

PAG

NEW!



- Aluminium die cast body
- Ergonomic steel pistol handle for fatigue free usage
- Venturi mechanism: Side ports combines free ambient air with costly compressed air creating a larger volume of usable output



SCAN TO WATCH

METAL BODY AIR BLOW GUN

AP

- Aluminium die cast pistol style air blow gun
- Variable flow trigger for controlling the air output
- Built-in storage hook for safe keeping when not in use
- Maximum pressure: 90 PSI
- Flow rate: 40 CFM



NEW!

Kit Constituents

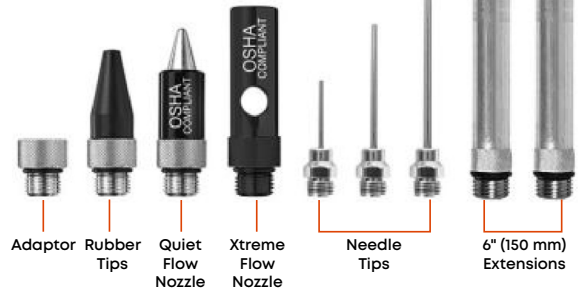

7 PIECE AIR BLOW GUN PROFESSIONAL

KIT-ABG

Interchangeable accessories include:

- 4" (100 mm) Protective Shield for safety in use from flying chips etc.
- 1" (25 mm) Rubber Tip for blowing out lines & cavities
- 1-3/8" (35 mm) Rubber tip for blowing out lines & cavities
- Soft Rubber Star Tip Nozzle for use on delicate materials
- Venturi Nozzle turbo charges output. Great for blowing out bondo dust, drying off & washing parts fast
- 1/2" (12.7 mm) Rubber Tip for blowing out lines & cavities

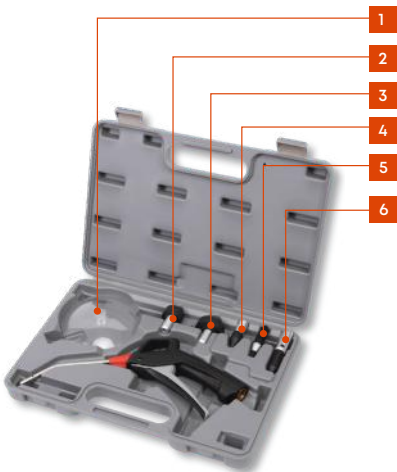

METAL BODY LEVER AIR BLOW GUN KITS

KIT-LAG

- Available in several configurations



POLYURETHANE RECOIL HOSES



145 PSI (10 BAR)

PUH

- One coiled end and one straight end
- Both ends fitted with polyacetal bend restrictors with solid brass swivel fittings for complete flexibility
- Burst Pressure: 508 PSI (35 BAR)
- Available in following lengths: 5ft (1.5 m), 10ft (3 m), 15ft (4.5 m), 20ft (6 m) and 25 ft (7.5 m) in 1/4" & 3/8" threads

**25%
LIGHTER
THAN RUBBER**



**METAL BODY LEVER AIR BLOW GUNS
(WITH BUILT-IN VENTURI)**



LAG

TYPE: A
1/2" (13 mm)
rubber tip



TYPE: B
Standard



TYPE: C
Standard safety



TYPE: D
High flow safety



TYPE: E
Safety booster



TYPE: F
Safety tamper proof



TYPE: G
1" (25 mm) rubber tip



TYPE: H
1-3/8" (35 mm) rubber tip



TYPE: J
Soft rubber star tip



TYPE: PS
Nozzle with 4" (100 mm) protective shield



TYPE: K
Nylon screen 1-1/4" (32 mm) wide



TYPE: L
Nylon tapered tube 3" (75 mm) long



TYPE: M
Mini aluminum tip



TYPE: NI
SS needle 1-3/4" (44 mm) long x
0.072" (1.8 mm) dia.



TYPE: N2
SS needle 2-15/32" (62 mm) long x
0.095" (2.4 mm) dia.



TYPE: P
Adjustable brass tip



TYPE: S
Nozzle with steel
wire brush



TYPE: T1
Extended reach aluminum tube
3" (75 mm) long



TYPE: T4
Extended reach aluminum
tube 12" (300 mm) long



TYPE: T2
Extended reach aluminum tube
6" (150 mm) long



TYPE: T3
Extended reach aluminum tube
9" (225 mm) long



TYPE: R
Extended reach telescopic tip
14" (355 mm) to 24" (610 mm)



TYPE: Q
Extended reach 23" (585 mm) long
with rubber tip



AIR COUPLERS & PLUGS

TYPE: M STYLE AIR COUPLER & PLUG
Milton Interchange Industrial



AIR COUPLER

AIR PLUG

TYPE: T STYLE AIR COUPLER & PLUG
Tru Flate / Parker Interchange Automotive



AIR COUPLER

AIR PLUG

TYPE: A STYLE AIR COUPLER & PLUG
Aero Interchange



AIR COUPLER

AIR PLUG

TYPE: L STYLE AIR COUPLER & PLUG
Lincoln Interchange Automotive



AIR COUPLER

AIR PLUG

TYPE: N STYLE AIR COUPLER & PLUG
Nitto Interchange



AIR PLUG

TYPE: AMT STYLE AIR COUPLER & PLUG
Universal Retail



AIR COUPLER

AIRLINE FITTINGS

NPL-RP

Threads:
1/4" NPT (M)

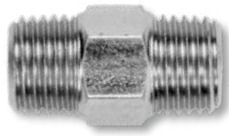

NPL-KP71

Threads:
1/4" BSP (M)

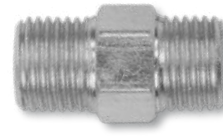

COOLANT MIXERS

- Ensures accurate and uniform blending of metal cutting fluids, coolants, antifreeze etc with water for supply to machines.

CMX

Coolant/liquid mixers with one piece polypropylene suction tube, 2" bung adaptor & delivery hose. Press fit plastic suction tube can be cut to fit drum height

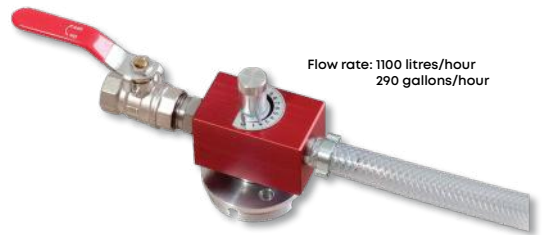

Flow rate: 1100 litres/hour
290 gallons/hour

CMX-SS

Coolant/liquid mixers with stainless steel 2pc threaded suction tube & 2" bung adaptor & delivery hose

CMX-1



CMX-2



CMX-3



TYRE PRESSURE GAUGE

TYG

- Compact pocket size air pressure gauge
- Pressure range from 10-50 PSI
- Metallic wear & tear resistant body
- Accuracy ± 1 PSI

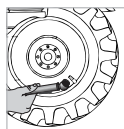

Mate the mouth of the tyre pressure gauge with the air valve of the tyre

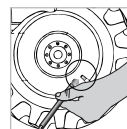

Press the tyre pressure gauge on the valve



Check the reading on the pressure reading tube that slides out of the tyre pressure gauge



TYRE INFLATOR GAUGES

TYRE INFLATOR GAUGE FOR CARS

TIG-12

The 3 in 1 Tyre Gauge is designed to:

- a. Measure Tyre Pressure
- b. Inflate Tyres
- c. Deflate Tyres
- Complete with 12" (300 mm) flexible hose with straight chuck & gauge
- Aluminium die cast gun with flexible hose and straight chuck suitable for cars & other light vehicles
- Gauge dia.: 2-1/2" (63 mm)



TYRE INFLATOR GAUGE V SERIES



UPTO 60 PSI (4 BAR)

TIG-25

The 3 in 1 Tyre Gauge is designed to:

- a. Measure Tyre Pressure
- b. Inflate Tyres
- c. Deflate Tyres
- Analog gauge with protective shroud
- Gauge dia: 2-1/2" (63 mm)
- Aluminium die cast gun with 17" (440 mm) flexible hose and straight chuck suitable for cars & other light vehicles
- Accuracy: ±4% of full scale



TYRE INFLATOR GAUGE FOR TRUCKS

FOR ANALOG GAUGE



UPTO 210 PSI (15 BAR)

FOR DIGITAL GAUGE



UPTO 300 PSI (21 BAR)

TIG-24

The 3 in 1 Tyre Gauge is designed to:

- a. Measure Tyre Pressure
- b. Inflate Tyres
- c. Deflate Tyres
- Aluminium die cast gun with flexible hose, rigid extensions & dual chuck suitable for attachment on valves of large tyres
- Gauge dia.: 2-1/2" (63 mm)



TYRE INFLATOR GAUGE FOR CARS - CEE GAUGE



UPTO 140 PSI (10 BAR)

TIGCEE-12

The 3 in 1 Tyre Gauge is designed to:

- a. Measure Tyre Pressure
- b. Inflate Tyres
- c. Deflate Tyres

Tyre Inflator With

- Analog Gauge
- Accuracy: ±0.08% < 4 BAR (58 PSI)
- ±1.6% > 4 BAR (58 PSI)



TYRE INFLATOR GAUGE FOR TRUCKS - CEE GAUGE



UPTO 140 PSI (10 BAR)

TIGCEE-24

The 3 in 1 Tyre Gauge is designed to:

- a. Measure Tyre Pressure
- b. Inflate Tyres
- c. Deflate Tyres

Tyre Inflator With

- Analog Gauge
- Accuracy: ±0.08% < 4 Bar (58 PSI)
- ±1.6% > 4 Bar (58 PSI)



industries

we serve

agriculture
automotive
aviation
chemical
construction
cement
DIY
electrical
industrial
marine
mining
oil & gas
plumbing
railway
steel welding
woodworking
workshop

terms & conditions

Intellectual Property: The intellectual property of this catalogue is assigned to all countries of the world. Reproduction, full and/or partial adaptation of its content (content, images, diagrams, icons, specifications, tables etc.) by any means without prior written permission from GROZ entails a violation of GROZ ENGINEERING TOOLS's copyrights and constitutes an act of unfair competition.

Technical Data: All drawings, weights, dimensions, the descriptions & illustrations contained in the company's catalogues are only approximate and intended merely to give a general description of the goods described therein.

Specifications: The information contained in this catalogue is as accurate as possible and complies, as far as possible with existing regulations at the time of its publication - OCTOBER 2023. We therefore reserve the right to make modifications in line with modifications to regulations and/ or product specifications, drawings, illustrations for continual improvement. Buyers must ensure that goods are suitable for the purpose intended. Imperial dimensions shown as equivalents to metric and vice-versa are approximate.

Delay in Delivery: Delay in completion of work, delivery or in case of a contract for delivery by installments, delay in delivery of an installment shall not give rise to any liability upon the company whether or not any time of date is given in this respect and shall not entitle the customer to terminate the contract.

Liability: All goods are guaranteed to do the work for which they are designed. If the goods or any part thereof are defective solely as a result of faulty materials or workmanship of the company, the company's liability shall be limited, at its discretion either to replacing such goods or the defective parts. But no such liability shall arise unless notification of any defect is received by the company in writing within 90 days from the receipt of goods by the buyer and the allegedly defective goods are thereafter returned to the company carriage paid with appropriate pre-notification.

Indemnity: The customer shall indemnify the company against all claims in respect of any loss, injury or damage sustained by a third party arising from the sales of the goods to the buyer how so ever caused and also against all actions, proceedings, costs, claims, demands and expenses made, brought or claimed against the company in respect of the infringement of any patent, trademark or registered design.

FLUID

FLU

FLU

ID FLA

FLU



Groz Engineering Tools Pvt. Ltd.
Groz Net Industries

Village Kherki Daula, National Highway-8
Gurugram -122004, Haryana, INDIA
TEL +91.124.282.7700
E-MAIL info@groz-tools.com
URL www.groz-tools.com

CONNECT WITH US!



The GROZ name, GROZ logo and the  mark are trademarks of Groz Engineering Tools Pvt. Ltd., India